



# SmartFind M6 AIS CLASS A

## INSTALLATION MANUAL



## General Information

### Volume 2 of 2

INSTALLATION MANUAL, refer to the separate USER MANUAL for operational guidance.

#### i. **Copyright**

The entire contents of this instruction manual, including any future updates, revisions, and modifications, shall remain the property of Netwave Systems B.V. at all times. Unauthorized copies or reproduction of this manual, either in part or whole, in any form of print and electronic media, is prohibited. The contents herein can only be used for the intended purpose of this manual.

#### ii. **Disclaimer**

The information and illustrations contained in this publication are to the best of our knowledge correct at the time of going to print. We reserve the right to change specifications, equipment, installation and maintenance instructions without notice as part of our policy of continuous product development and improvement. No part of this publication may be reproduced, stored in a retrieval system or transmitted in any form, electronic or otherwise without permission in writing from Netwave Systems B.V. No liability can be accepted for any inaccuracies or omissions in the publication, although every care has been taken to make it as complete and accurate as possible. This manual is applicable for McMurdo Smartfind M6 units manufactured after March 2024.

#### iii. **Safety Warning**



It is important to know that AIS is designed for the purpose of anti-collision and serves as a complement to navigation. It is not the absolute navigational equipment and does not replace any navigational system installed on board.

Any AIS device cannot guarantee the monitoring and receiving of signals from all vessels in the surroundings.



#### **ELECTRICAL SHOCK HAZARD**

Improper disassemble or modification could cause electrical shocks, fire, or personal injury. Contains no user-serviceable parts. Only suitably qualified personnel should attempt repair of the equipment.

### **CORRECT POWER SOURCE**



Incorrect power sources will damage the equipment and may even result in fire.

Please ensure the correct power source is provided at all times.

### **AVOID DIRECT CONTACT WITH RAIN OR SPLASHING WATER**



Electrical shock or fire could be resulted if water leaks into the equipment.

### **RADIO LICENCE**



The AIS transponder is a maritime radio transmitter. Some administrations may require that the user holds a valid radio license to cover its ownership and use.

### **RADIO FREQUENCY RADIATION HAZARD**



The AIS transponder emits low levels of radio frequency radiation. It is the operator's responsibility to ensure that no personnel come within the Maximum Permissible Exposure (MPE) radius of 1.9 m from the antenna.

### **NOTE/INFORMATION**



Throughout this manual this symbol indicates important information.

#### **iv. Product Category**

This product is categorized as “protected” in accordance with the requirements as defined in IEC 60945.

#### **v. Compass Safe Distance**

Safe distance to the transponder (and junction box) unit is:  
Standard-magnetic-compass: 0.30 m  
Steering-magnetic-compass: 0.30 m

#### **vi. RF Exposure Safe Distance**

The AIS transponder has been tested and meets applicable limits for radio frequency (RF) exposure. This device generates and radiates RF

electromagnetic energy and requires a Maximum Permissible Exposure (MPE) no entry zone for all personnel of 1.9 m radius around the antenna during its operation.

**vii. Hardware / Software Version**

The model name/number, hardware information, and firmware (software) version of the transponder can be identified through MKD at MENU/DIAGNOSTICS/VERSION. The software maintenance/upgrade of the transponder can be carried out on board via MicroSD card. The onboard documentation as described in the installation manual Appendix C can be used to assist reflecting software maintenance records.

**viii. Type Approval**

The AIS transponder complies with applicable international standards and is type approved in accordance with the European Marine Equipment Directive.

**ix. Declaration of Conformity**

Hereby, Netwave Systems B.V. declares that the McMurdo Smartfind M6 Class A AIS transponder is in compliance with the essential requirements and other relevant provisions of European MED Directive 2014/90/EU. A full list of applicable national type approvals and Declaration of Conformity(s) can be obtained on-line from:

[https://www.seasofsolutions.com/products/?\\_sft\\_technology=ais-electronics](https://www.seasofsolutions.com/products/?_sft_technology=ais-electronics)

**x. UK Declaration of Conformity**

McMurdo Ltd declares that this equipment is in conformity with the Merchant Shipping (Marine Equipment) Regulations 2016 as amended under Annex 1 of MSN 1874, as amended including Compliance Requirements for UK/4.32.

A copy of the Manufacturers Declaration of Conformity can be obtained online from: <https://www.seasofsolutions.com/products/>

**xi. Disposal Instruction**

The Waste Electrical and Electronic Equipment (WEEE) Directive aims to minimize any adverse impact of electronic equipment on the environment, both during the product lifetime and when it becomes

waste. Within the European Union this legislation is mandated by Directive 2002/96/EC, and there is similar legislation in most other continents. The directive applies to all electronic products such as IT, household appliances, portable electronics etc., and imposes requirements to collect, treat, recover and recycle each product at its end of life. Do not dispose of this device with unsorted waste. Improper disposal may be harmful to the environment and human health. Please refer to your local waste authority for information on return and collection systems in your area.

**xi. IMO Green Passport Ship Recycling Information**

Netwave Systems B.V. hereby declares potentially hazardous content in some of its electronic products. In keeping with European directive 2002/96/EC (Waste Electronic and Electrical Equipment) and the provisions of IMO Resolution A.962(23) (Guidelines On Ship Recycling), Netwave Systems B.V. strongly recommends that its products, including any battery packs, be disposed of in a considerate and legal manner.

**xii. Maintenance and contact information**

All servicing must be carried out by a Netwave Systems B.V. approved service agent. Always call your nearest agent and talk to their service department before returning equipment.

**xiii. Product Warranty**

As standard, your unit has a one year (12 months) warranty from the date of purchase shown on your invoice, however, this can be extended by a further one year by simply registering your unit on-line within 90 days of purchase at: <https://www.seasofsolutions.com/contact-us/warranty-registration/>

Warranty enquiries should be sent to:

Email: [info@seasofsolutions.com](mailto:info@seasofsolutions.com)

Telephone: +44 (0) 239262 3900

Or by mail to:

Netwave Systems B.V.

Blauw-roodlaan 100, 2718 SJ Zoetermeer, Netherlands.

or

McMurdo Ltd

Holbrook Court, E1 Cumberland Business Centre,

Northumberland Road, Southsea, Hampshire, PO5 1DS, UK

## TABLE OF CONTENTS

<b>1</b>	<b>M6 SYSTEM OVERVIEW .....</b>	<b>3</b>
1.1	PRODUCT DESCRIPTION.....	3
1.2	M6 MAIN FEATURES .....	3
1.3	INTERCONNECTION DIAGRAM.....	4
<b>2</b>	<b>INSTALLATION 5</b>	
2.1	EQUIPMENT IN THE BOX.....	5
2.2	INSTALLATION PROCEDURES .....	6
2.3	RF CABLE REQUIREMENTS .....	6
2.4	VHF ANTENNA INSTALLATION .....	7
2.5	GNSS (GPS) ANTENNA INSTALLATION.....	8
2.6	MOUNTING M6 MAIN UNIT.....	8
	2.6.1 Mounting M6 Transponder Main Unit.....	9
	2.6.2 Mounting Junction Box.....	11
2.7	M6 EXTERNAL CONNECTORS (TRANSPONDER MAIN UNIT).....	12
2.8	EXTERNAL CONNECTORS (JUNCTION BOX) .....	13
2.9	CONNECTING EXTENSION CABLE .....	16
2.10	CONNECTING TO POWER SUPPLY .....	17
2.11	PILOT PLUG CONNECTION.....	17
2.12	PASSWORD SETTING.....	18
<b>3</b>	<b>PRODUCT SPECIFICATIONS.....</b>	<b>19</b>
3.1	APPLICABLE STANDARDS.....	19
3.2	VHF TRANSCEIVER.....	19
3.3	DSC RECEIVER .....	19
3.4	GNSS RECEIVER (INTERNAL).....	20
3.5	POWER SUPPLY .....	20
3.6	LCD DISPLAY .....	20
3.7	KEYPAD.....	20
3.8	CONNECTION INTERFACE .....	21
3.9	ENVIRONMENTAL.....	22
3.10	PHYSICAL .....	22
3.11	PILOT PLUG (OPTIONAL).....	22
<b>4</b>	<b>MECHANICAL DIMENSIONS .....</b>	<b>23</b>

4.1	M6 TRANSPONDER MAIN UNIT .....	23
4.2	JUNCTION BOX .....	25
4.3	EXTENSION CABLE.....	25
4.4	ETHERNET CABLE .....	25
4.5	MOUNTING TEMPLATE (NOT TO SCALE) .....	26
4.6	GNSS (GPS) ANTENNA GA-25 .....	26
4.7	PILOT PLUG SOCKET BOX (OPTIONAL) .....	27
<b>5</b>	<b>TROUBLESHOOTING .....</b>	<b>28</b>
5.1	TROUBLESHOOTING WITH ALARM MESSAGES .....	29
<b>APPENDIX A: TECHNICAL INFORMATION - DATA INTERFACE .....</b>		<b>31</b>
A.1	AIS INTERFACE OVERVIEW .....	31
A.2	M6 DATA INTERFACE (IEC 61162-2) .....	32
A.3	SUPPORTED IEC 61162 DATA SENTENCES .....	34
A.4	INTERPRETATION OF INPUT SENTENCES .....	34
A.5	INTERPRETATION OF OUTPUT SENTENCES.....	49
<b>APPENDIX B: M6 NMEA 2000 PGN INFORMATION.....</b>		<b>56</b>
<b>APPENDIX C: INSTALLATION AND MAINTENANCE RECORD .....</b>		<b>58</b>
<b>APPENDIX D: USCG CHECK LIST &amp; REPORT .....</b>		<b>60</b>
<b>6</b>	<b>DOCUMENT REVISIONS .....</b>	<b>62</b>



# 1 M6 SYSTEM OVERVIEW

## 1.1 Product Description

The **McMurdo SmartFind M6** is a new generation **AIS Class A transponder** fully compliance with IMO, IEC, and ITU international standards. It provides a compact single box solution, easy to install and operate. The product is designed with advanced technology which sets a new standard for quality, performance, and value. It is an excellent choice for SOLAS vessels, commercial ships, professional vessels, and non-SOLAS applications.

The M6 can be connected to the ship's sensors as required by the IALA guidelines through junction box. The device can also interface external navigation and presentation systems that support IEC 61162-1 related sentences. It is also capable for connection to Long Range systems like Inmarsat C. The M6 supports both SOLAS and Inland AIS mode which is configurable by the software.

The colour LCD display and menu keypads provide an intuitive graphical user-friendly interface to the system. It can display the location of other vessels, aids to navigation and search and rescue vessels. The AIS transmit and receive status are shown on the screen which helps user to know the working status of the unit easily. The LCD and keypad can also be used to send and receive messages, perform configuration as well as supervise the system status.

## 1.2 M6 Main Features

- Compact AIS Class A solution, easy to install and operate
- Fully compliant with IMO, IEC, and ITU international standards
- Color 4.3" LCD display with variant display modes
- User-friendly intuitive GUI & keypad operation
- IMO/Inland AIS mode selectable
- Compliance with CESNI Inland AIS test standard Ed. 2021/3.0
- Multiple sensor input ports and bi-directional data ports
- USB, NMEA 0183, NMEA 2000, Ethernet connectivity, and SD card for software upgrade
- Support type P of BAM function type

# 1.3 Interconnection Diagram

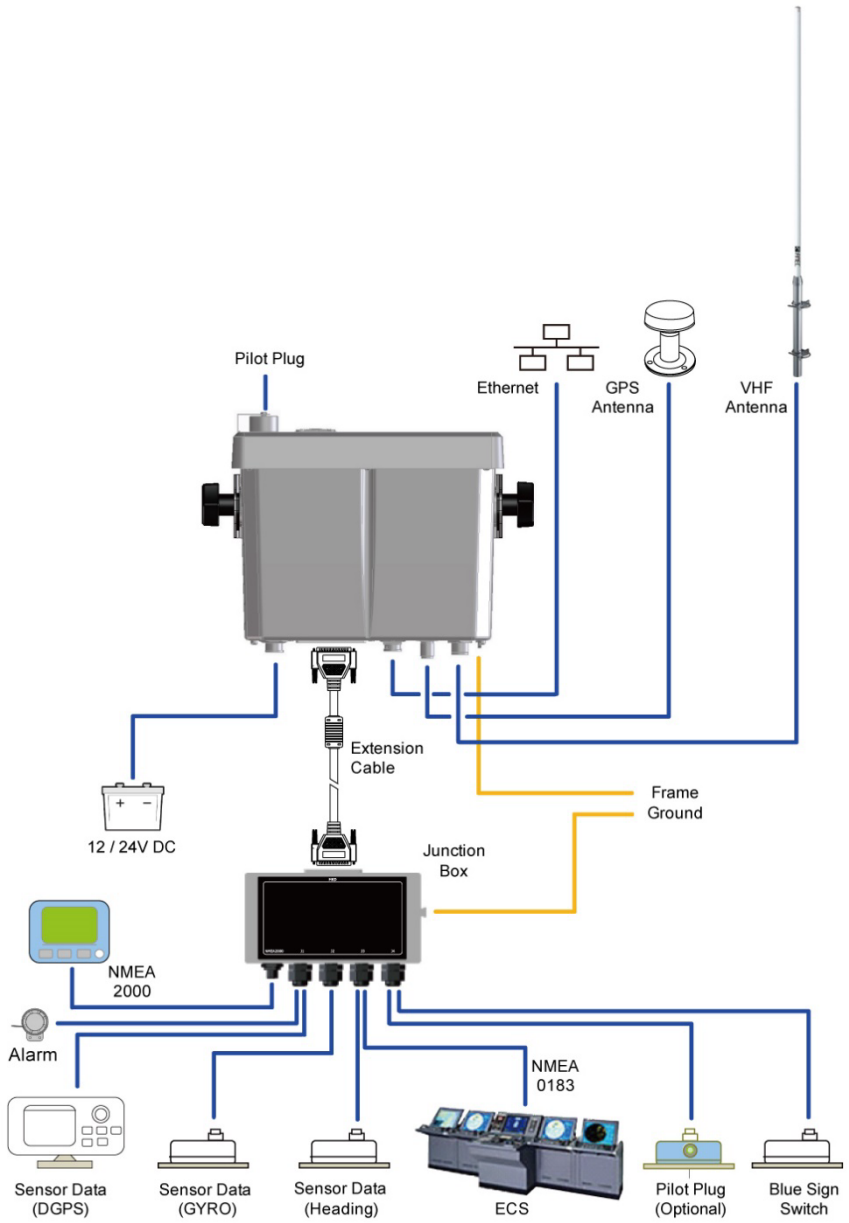

# 2 INSTALLATION

## 2.1 Equipment in the Box

The standard supply in the package includes the following items. Please contact your local representative if any item is missing.

---



Class A AIS Transponder unit



Junction box

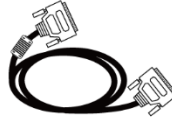

37-pin extension cable 1.8m



3-pin power cable 1.5m



U-shaped mounting bracket kit

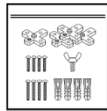

Junction box mounting kit

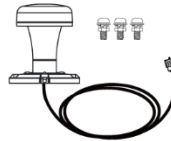

GPS antenna GA-25 with 10m cable

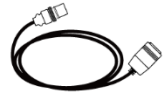

8-pin Ethernet cable (RJ-45 female)

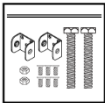

Panel mount holder kit

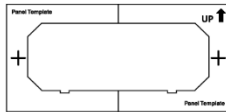

Panel mount cutting template



Installation manual and Operator manual

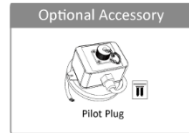

Optional Accessory

Pilot Plug

## 2.2 Installation Procedures

Please familiarize yourself with the manual contents before beginning the installation. Use the following recommended steps for installation.

- 1) Mount the transponder unit to a desired location
- 2) Mount junction box
- 3) Install VHF antenna
- 4) Install GPS antenna
- 5) Connect all external sensors and data interfaces to the junction box
- 6) Connect all required cables to the main transponder unit
- 7) Power on the main transponder unit
- 8) Complete configuration setting
- 9) Perform system functional test

## 2.3 RF Cable Requirements

The following RF cables are recommended to install the M6.

### ■ VHF Antenna Cable

Type: RG214, 5D-FB or equivalent

Connector: PL-259 (Male)

### ■ GPS Antenna Cable

Type: RG58A/U or equivalent

Connector: TNC (Male)

Cable and connector are supplied as part of the GPS antenna.

## 2.4 VHF Antenna Installation

The quality and positioning of the antenna are the most important factors dictating AIS performance. It is recommended that a VHF antenna with omni directional vertical polarization be specifically tuned for AIS operation band. Since the range of VHF signals is largely decided by line of sight distance, the VHF antenna should be placed as high as possible and at least 5 meters away from any constructions made of conductive materials.

To avoid interference, the VHF antenna location should be placed accordingly as diagram below:

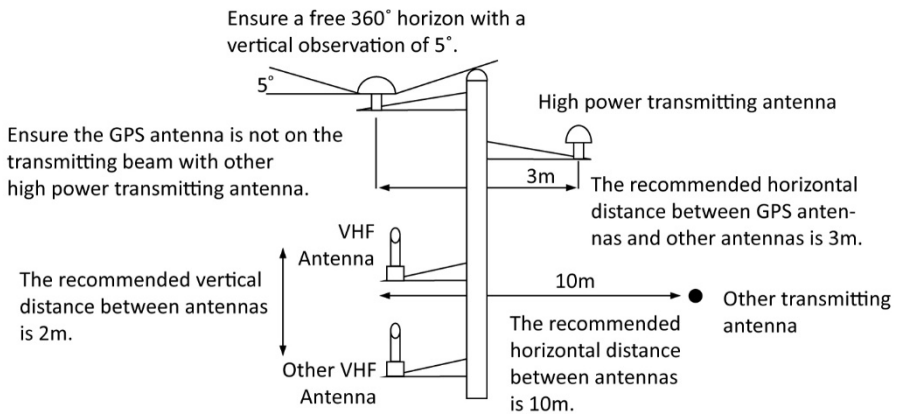

Figure 1 VHF/GPS Antenna Locations

## 2.5 GNSS (GPS) Antenna Installation

The GPS antenna must be installed where it has a clear view of the sky, so that it may access the horizon freely with 360 degrees, with a vertical observation of 5 to 90 degrees above the horizon.

### GPS ANTENNA LOCATION

Enter the GPS antenna location data in “SHIP SETTING” after the installation.

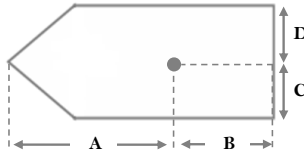

Figure 2 GPS Antenna location

## 2.6 Mounting M6 main unit

Use the following guidelines to check the installation location for your AIS transponder:

- The AIS transponder should be mounted in a location that is accessible and readable to user at all time.
- The transponder should be installed in a protected environment away from direct rain and water contact.
- The transponder is designed to operate in an environment with  $-25\text{ }^{\circ}\text{C} \sim +55\text{ }^{\circ}\text{C}$  temperature. Environments with excessive heat may cause damages to the transponder.
- The transponder should not be installed near flammable or hazardous environments.
- The AIS transponder should be installed at least 0.5 m away from magnetic compasses.

## 2.6.1

### Mounting M6 Transponder Main Unit

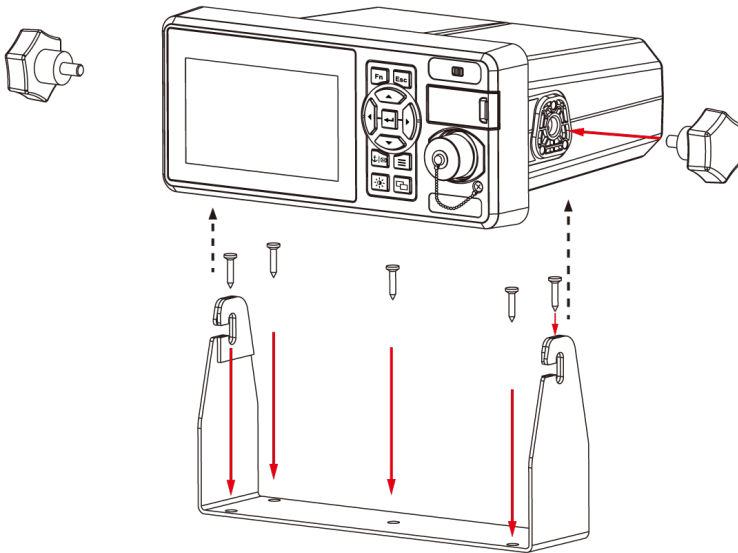

Figure 3 Mounting M6 Main Unit

#### Panel Mounting (1)

1. Line up the mounting template on control panel to sketch an outline for the cutting area.
2. Using a jigsaw carefully cut along the sketched cutting area.
3. If necessary, clean up edge with glass paper or file.
4. Mount the transponder through the opening.
5. From the rear, install the mounting brackets with the M3X6 screws.
6. Apply the mounting bracket screw (brackets are directional, ensure correct one is fitted to each side) on each side for a firm fix.

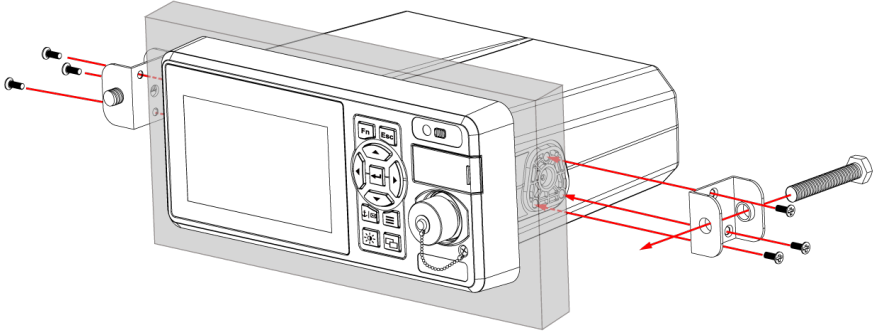

Figure 4 Panel Mounting (1)

**Panel Mounting (2)**

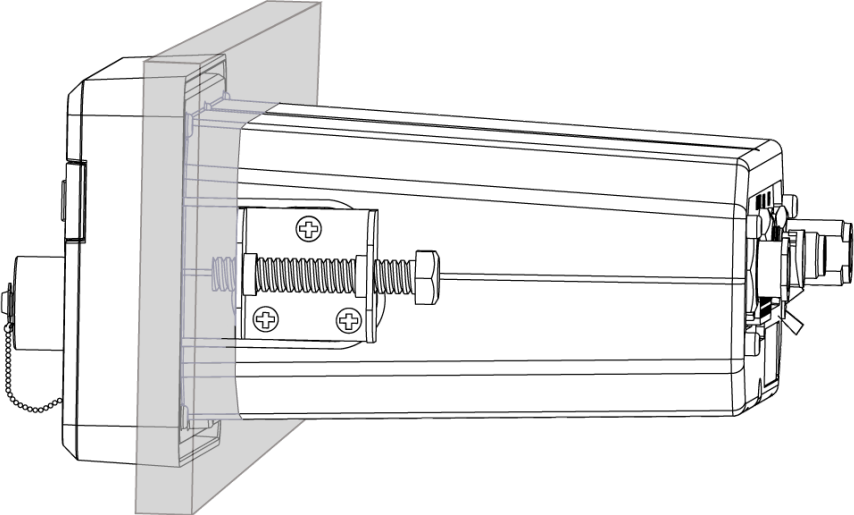

Figure 5 Panel Mounting (2)



## 2.6.2 Mounting Junction Box

### Mounting Junction Box (1)

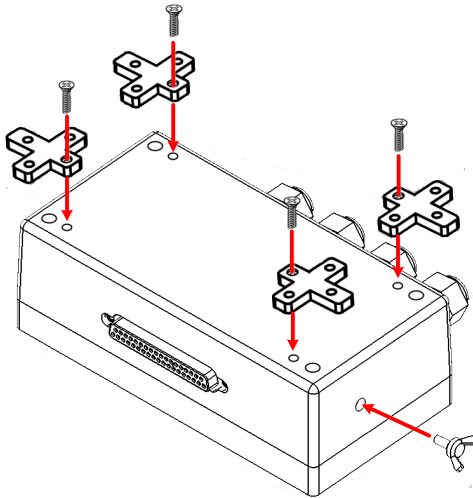

Figure 6

### **Mounting Junction Box (1)**

### Mounting Junction Box (2)

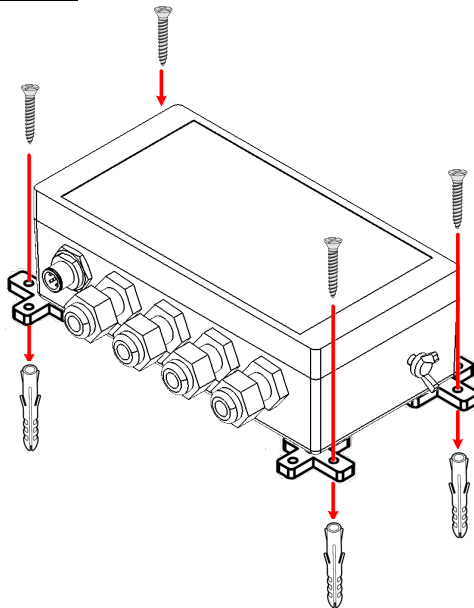

Figure 7

### **Mounting Junction Box (2)**

## 2.7 M6 External Connectors (Transponder Main Unit)

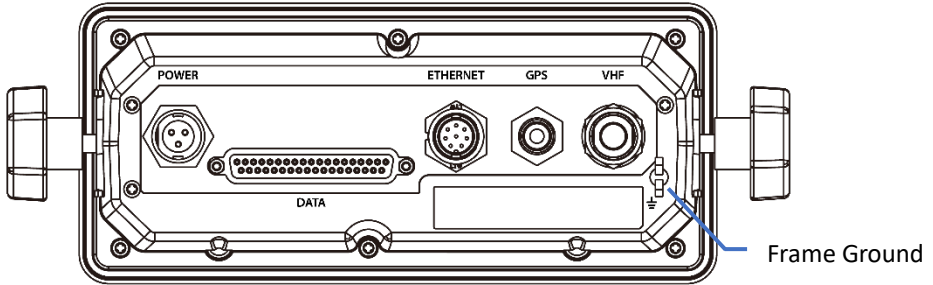

Figure 8 M6 Rear View

NAME	DESCRIPTION	TYPE
<b>POWER</b>	Power input connector	Round type, 3 pins
<b>ETHERNET</b>	10Base-T/ 100Base-TX	Round type, 8 pins
<b>GPS</b>	GPS antenna connector	TNC (female)
<b>VHF</b>	VHF antenna connector	SO-239 (female)
<b>DATA</b>	Connect to Junction Box/ Connect to sensor or data ports	D-Sub 37 pins
<b>Frame Ground</b>	Connect to ship frame	

### Vessel power supply requirement

Connect to the ship's power source, ideally an uninterrupted power supply (UPS), through a 2-pole switched fused supply to allow isolation for servicing. Power requirement is typical 24 V DC (2 A minimum) or 12 V DC (4 A minimum). Required conductor area, cable length 0-10 m is 1.5 mm<sup>2</sup>  $\varnothing$  minimum.



**M6 will turn on and start operating as soon as the DC power is applied.**  
Use the remote isolation switch if it's required to turn off the M6.

**Note:** The Class A power supply requirement should comply with IMO guidelines for the class of vessel concerned. National authorities and classification societies may have their own power supply requirements; these should also be considered.

**Note:** Some boats require frame ground connection of all electronic devices on the ship frame.

## 2.8 External Connectors (Junction Box)

Baud rate support: 115200, 57600, 38400, 19200, 14400, 9600, 4800.

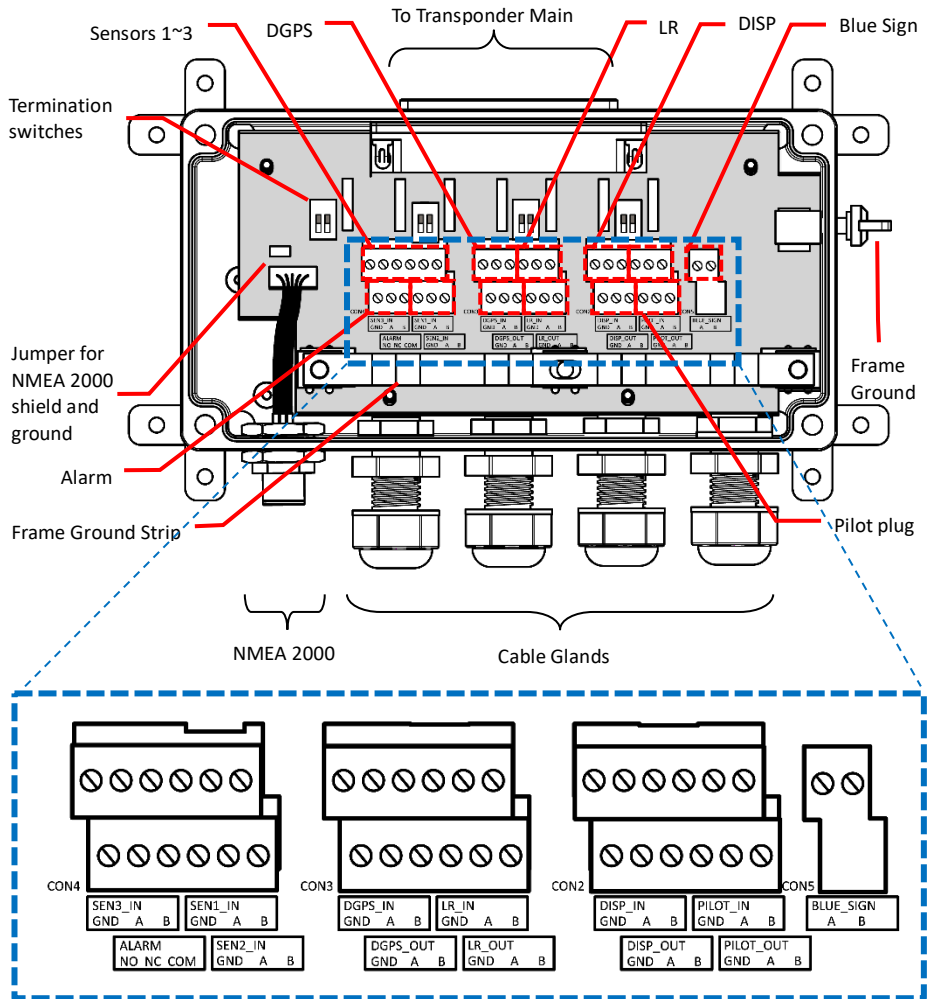

Figure 9 External Connectors (Junction Box)

CONNECTOR	LABEL NAME	DESCRIPTION	FUNCTION USAGE
<b>Sensor 1</b> *1)	GND	Ground	Connect to data sources such as heading, gyro, or other type of sensors.
	SEN1_IN A	Sensor 1 input A	
	SEN1_IN B	Sensor 1 input B	
<b>Sensor 2</b> *1)	GND	Ground	Connect to data sources such as heading, gyro, or other type of sensors.
	SEN2_IN A	Sensor 2 input A	
	SEN2_IN B	Sensor 2 input B	
<b>Sensor 3</b> *1)	SEN3_IN GND	Ground	Connect to data sources such as heading, gyro, or other type of sensors.
	SEN3_IN A	Sensor 3 input A	
	SEN3_IN B	Sensor 3 input B	
<b>Pilot Plug</b> *2)	GND	Ground	Pilot plug port
	PILOT_IN A	Input A	
	PILOT_IN B	Input B	
	GND	Ground	
	PILOT_OUT A	Output A	
	PILOT_OUT B	Output B	
<b>Alarm</b>	ALARM NO	Alarm normally open	
	ALARM NC	Alarm normally close	
	ALARM COM	Alarm common	
<b>DGPS Input</b> *2)	GND	Ground	DGPS sensor
	DGPS_IN A	DGPS input A	
	DGPS_IN B	DGPS input B	
<b>DGPS Output</b> *2)	GND	Ground	DGPS sensor
	DGPS_OUT A	DGPS output A	
	DGPS_OUT B	DGPS output B	
<b>LR Input</b> *2)	GND	Ground	Long range input
	LR_IN A	LR input A	
	LR_IN B	LR input B	
<b>LR Output</b> *2)	GND	Ground	Long range output
	LR_OUT A	LR output A	
	LR_OUT B	LR output B	
<b>Display</b> *2)	GND	Ground	Connect to the data output of an external display system such as ECDIS.
	DISP_IN A	DISP input A	
	DISP_IN B	DISP input B	
	GND	Ground	Connect to the data input of an external display system such as ECDIS.
	DISP_OUT A	DISP output A	
	DISP_OUT B	DISP output B	
<b>Blue Sign</b>	BLUE_SIGN A		Connect to a blue sign switch.
	BLUE_SIGN B		

**NOTES:**

\*1) The default baud rate is 4800.

\*2) The default baud rate is 38400.

3) Suitable electric wire gauge (single wire) for installing Junction Box: AWG 26 ~ 16  
 See diagram below.

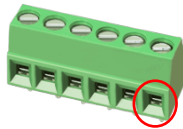

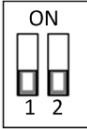
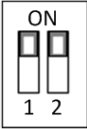
ITEM	USAGE
<p style="text-align: center;"><b>Termination Switches</b></p>	<p>The switches provide line termination configuration.</p> <div style="border: 1px solid black; padding: 10px; text-align: center;"> <div style="display: flex; justify-content: space-around;"> <div style="text-align: center;"> <p>Termination</p>  </div> <div style="text-align: center;"> <p>Termination</p>  </div> </div> </div>
<p><b>Jumper for NMEA2000 shield and ground</b></p>	<p>The jumper's purpose is to wire together NMEA 2000 cable's shield and ground. Depending on your scenario, you may choose not to connect them together.</p>

## 2.9 Connecting Extension Cable

Use the 37-pin- extension cable (1.8 M) provided in the package connect M6 to the junction box.

Note: The side of extension cable with a core should be connected close to the M6 main unit.

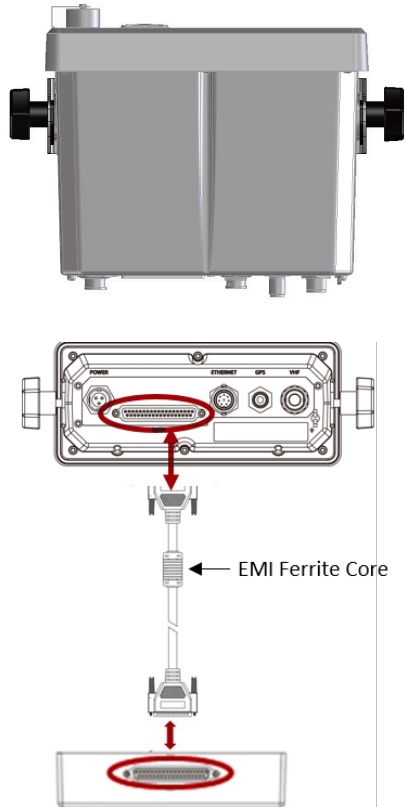

Figure 10 Connecting M6 with Junction Box

## 2.10 Connecting to Power Supply

The M6 requires a switched 12 V or 24 V DC power supply (9.6 to 31.2 V operation range) capable of supplying 4 A peak current. The red wire and the black wire on the 3-pin cable are used to connect the power supply's positive and negative terminals. A switched 4 Amp fuse or circuit breaker must be used in the connection between the power supply and the unit.

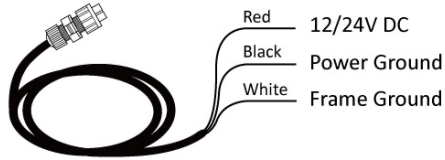

Figure 11 M6 Power Connection



**M6 will turn on and start operating as soon as the DC power is applied. Use the remote isolation switch if it's required to turn off the M6.**

## 2.11 Pilot Plug Connection

The M6 has an integrated pilot plug on the front panel with the IMO standard AMP connector. Open the waterproof lid to connect the PPU (Personal Pilot Unit). When needed, an optional pilot plug is available for purchase to be connected through the junction box.

It is recommended to keep the pilot plug lid closed when not in use.

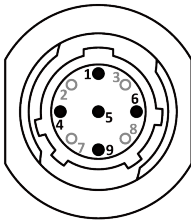

Pilot plug	Signal Type
Pin 9	RS-422 GND
Pin 1	RS-422 TX-A
Pin 5	RS-422 RX-A
Pin 4	RS-422 TX-B
Pin 6	RS-422 RX-B

## 2.12 Password Setting

This submenu enables change of the default operator password. Certain important settings stored within the transponder can only be changed using the operator password.

The Password is required for the access of the following chapters:

- Own ship - contains information about MMSI, vessel name, IMO, call sign and dimension.
- Long Range Settings -
- Long Range Broadcast -
- Transceiver - enables the option to activate/deactivate AIS transmission
- I/O Port Settings - about baud rate configuration of sensors

### Default password: "000000"

Use direction keys to select **Old Password**, **New Password** and then press  to enter value. To save the settings, press SAVE button in the view and the system will ask whether the changes should be saved. Select YES to save or NO to discard and return to System Configuration submenu.

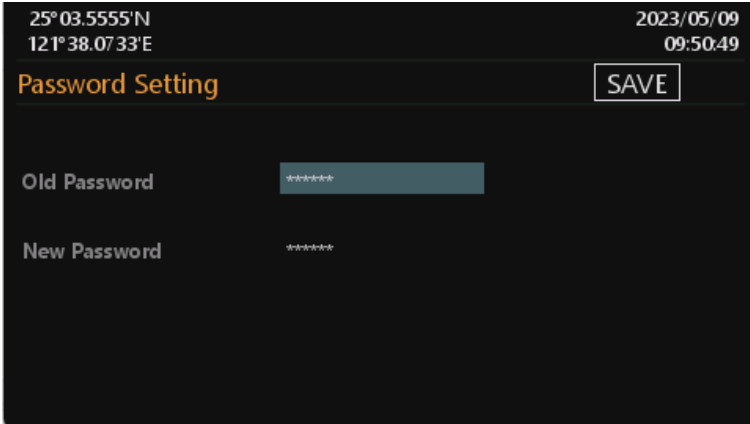

25°03.5555'N 2023/05/09  
121°38.0733'E 09:50:49

**Password Setting**

Old Password

New Password



## 3 PRODUCT SPECIFICATIONS

### 3.1 Applicable Standards

IEC 61993-2 Ed. 3.0 (2018-07)	IMO Resolution A.694(17) (1991-11)
IEC 61108-1 Ed. 2.0 (2003-07)	IMO Resolution MSC.74(69) Annex 3 (1998-05)
IEC 60945 Ed. 4.0 (2002-08) incl. Cor. 1 (2008-04)	IMO Resolution MSC.191(79) (2004-12)
IEC 61162-1 Ed. 5.0 (2016-08)	IMO Resolution MSC.302(87) (2010-05)
IEC 61162-2 Ed. 1.0 (1998-09)	ITU-R M.1371-5 (2014-02)
IEC 61162-450 Ed. 2.0 (2018 -05)	IEC 62288 Ed. 3.0 (2021 -12)
IEC 62923-1 Ed. 1.0 (2018 -08)	IEC 62923-2 Ed. 1.0 (2018 -08)
CESNI Inland AIS test standard Ed. 3.0 (2021)	

### 3.2 VHF Transceiver

Frequency	AIS 1: 161.975 MHz; AIS 2: 162.025 MHz
Channel Bandwidth	25 KHz
Modulation	GMSK / FM
Data Rate	9,600 bps
Number of AIS Transmitter	1
Number of AIS Receiver	2
Number of DSC Receiver	1
AIS Channel 1	CH 87B (161.975 MHz)
AIS Channel 2	CH 88B (162.025 MHz)
AIS Transmit Power	1/12.5 Watt (30/41 dBm $\pm$ 1.5 dB)
AIS Receive Sensitivity	< -107 dBm @ 20% PER

### 3.3 DSC Receiver

Frequency	156.525 MHz
Modulation	FSK
Channel Bandwidth	25K
Sensitivity	< -112 dBm @ 1% BER
Spurious Response Rejection	≥ 70 dB for signal @ -104 dBm; BER ≤ 1 %
Blocking	≥ 84 dB for signal @ -104 dBm; BER ≤ 1 %

### 3.4 GNSS Receiver (Internal)

Receiver type	72-channel; GPS, GLONASS, BeiDou, Galileo, SBAS: WASS, EGNOS, MSAS, GAGAN
Accuracy	Position: 2.5m CEP SBAS: 2.0m CEP
Sensitivity	Default mode: GPS & GLONASS Tracking & Navigation: -164 dBm Reacquisition: -160 dBm

### 3.5 Power Supply

Supply Voltage	12 V / 24 V DC
Supply Voltage Range	9.6 V DC ~ 31.2 V DC
Peak Current Draw	3.60 A @ 12 V DC; 1.72 A @ 24 V DC

### 3.6 LCD Display

Screen Size	4.3" color TFT
Pixel Number (Resolution)	480x272
Dimmer Control	Change brightness manually or automatically
Nominal Viewing Distance	52 cm

### 3.7 Keypad

11 Keypads with Back-light	Function, ESC, Voyage/SRM, MENU, Screen
----------------------------	---

Brightness, DISP, Enter, Arrow Keys
--

### 3.8 Connection Interface

<b><u>M6 Main Unit Front Panel:</u></b>	
USB	Mini type B USB interface
SD Card Slot	MicroSD type, support for exFAT and FAT32
Pilot Plug	Std. Sex 206486-2
<b><u>M6 Main Unit Rear Panel:</u></b>	
Power Connector	Round type, 3 pins
GPS Antenna Connector	TNC (Female)
VHF Antenna Connector	SO-239 (Female)
Ethernet	Compliance with IEC 61162-450
DATA	37-pins, connect to Junction Box via extension cable
<b><u>Junction Box Connectors:</u></b> [* Baud rate support: 38400, 9600, 4800.]	
Sensor Interfaces 1 to 3 *	IEC 61162-1 or -2
Pilot / Auxiliary *	IEC 61162-2
External Display *	IEC 61162-2
Long Range *	IEC 61162-2
DGNSS correction input *	RTCM-SC-104
Alarm Relay	Normally close
NMEA 2000®	IEC 61162-3
Alarm Output	Relay contact
Blue Sign Switch	Connect to external Blue sign switch

### 3.9 Environmental

Operating Conditions	IEC 60945 “protected” category
Operating Temperature	-25 °C ~ +55 °C
Operating Humidity	93 % RH at 40 °C
Waterproof and Dust Resistant	IP54

### 3.10 Physical

Width	262 mm (10.32 inch)
Height	135 mm (5.32 inch)
Depth (include connectors)	193.6 mm (7.62 inch)
Weight (main unit)	1.25 kg

### 3.11 Pilot Plug (optional)

Cable Length	2 m
Connector Type	Std. Sex 206486-2

## 4 MECHANICAL DIMENSIONS

### 4.1 M6 Transponder Main Unit

Front (size: mm)

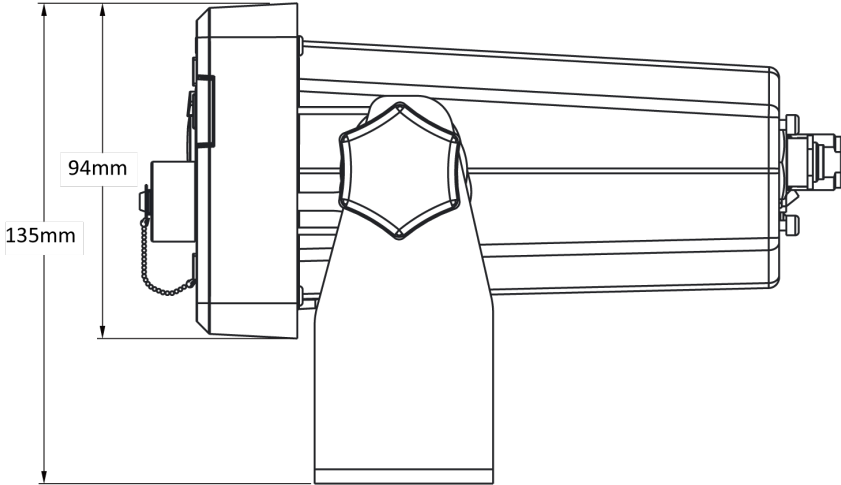

Side (size: mm)

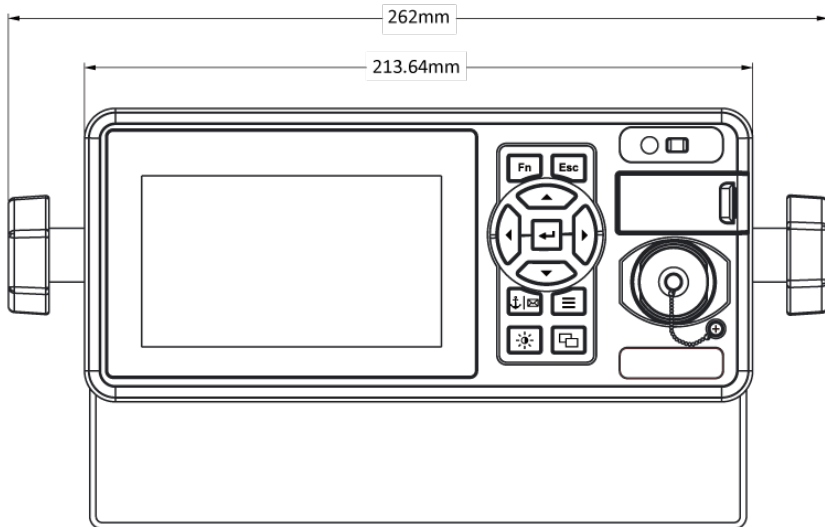

**Back (size: mm)**

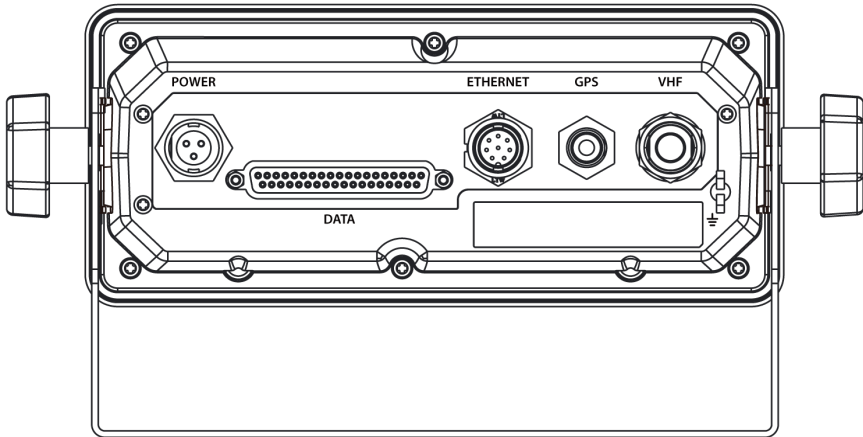

**Bottom (size: mm)**

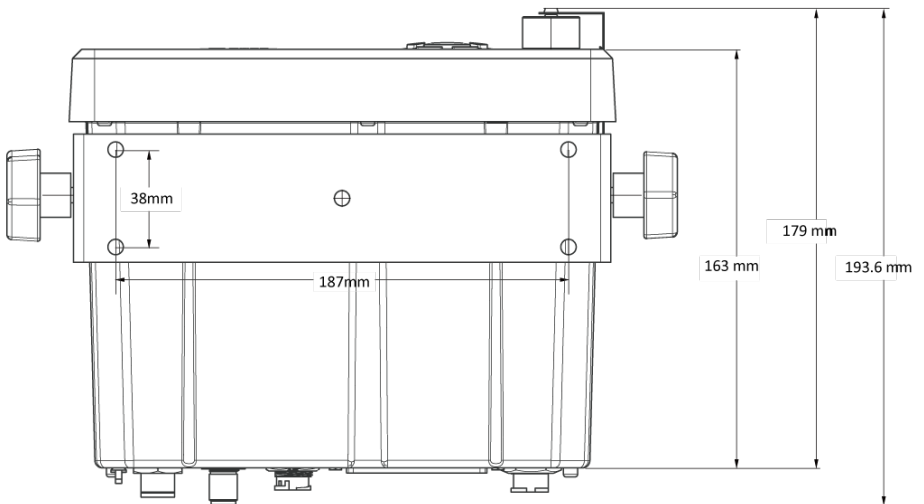

## 4.2 Junction Box

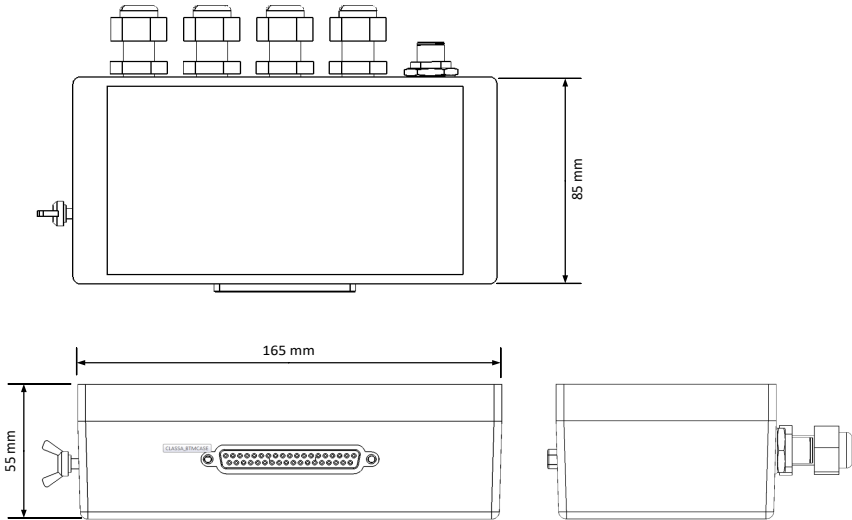

## 4.3 Extension Cable

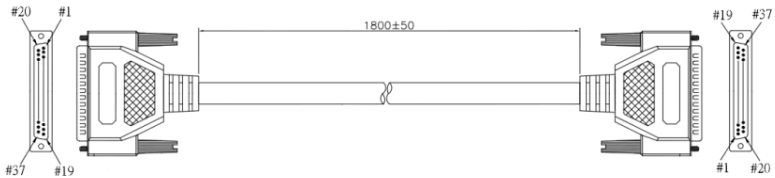

## 4.4 Ethernet Cable

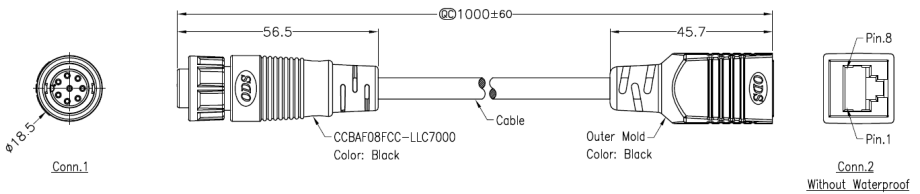

## 4.5 Mounting Template (not to scale)

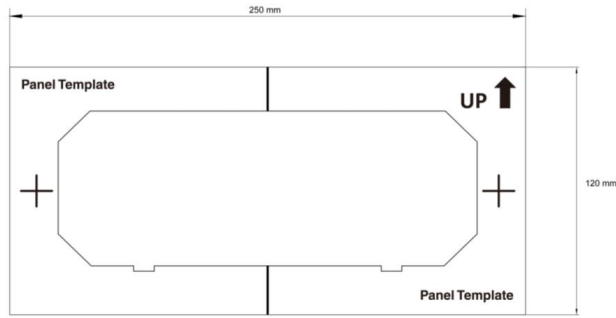

## 4.6 GNSS (GPS) Antenna GA-25

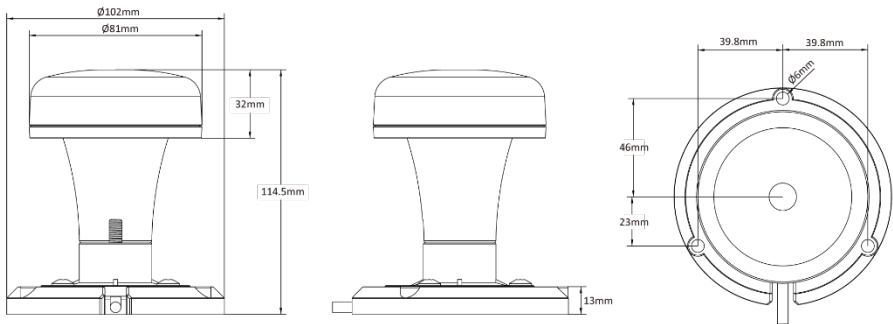



## 4.7 Pilot Plug socket box (optional)

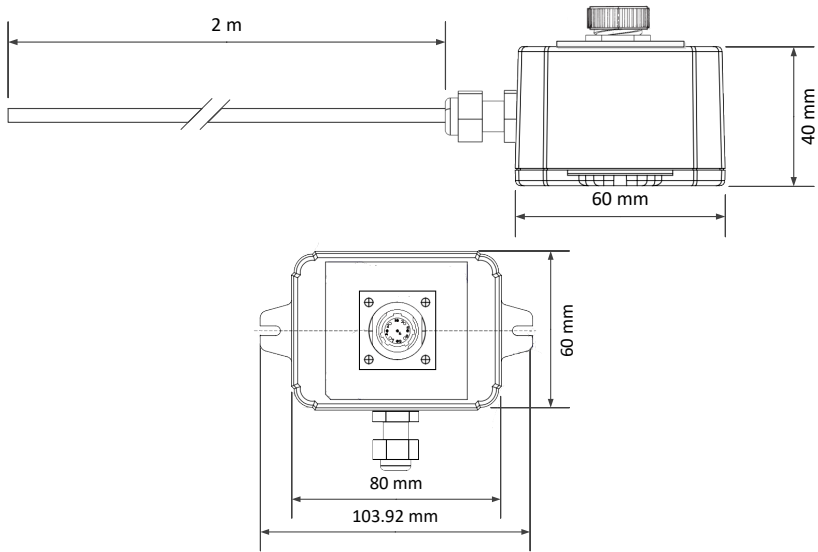

## 5 TROUBLESHOOTING

Use the following guide to perform simple troubleshooting in case the transponder does not function as it is expected. Due to the complexity of the operation environment of marine electronics, it is recommended to minimize all possible interference sources before proceeding with the troubleshooting by

- Disconnecting other NMEA equipment from the AIS transponder such as ECDIS, heading or gyro etc.
- Switching off other emission sources such as radar or VHF radio.

Symptom	Possible cause and remedy
<b>The transponder will not power on</b>	<ul style="list-style-type: none"> <li>• Check that the voltage of the power supply has 12 V or 24 V.</li> <li>• Check that the polarity is not switched.</li> <li>• Check that the available current is sufficient for start-up.</li> <li>• Check that the power connector is correctly connected and secured.</li> <li>• Increase Dimmer level of the display.</li> </ul>
<b>No GPS position fix</b>	<ul style="list-style-type: none"> <li>• Check for failed GPS antenna, damaged antenna cable and connectors</li> <li>• When the transponder's internal GPS does not have a position fix, the time and date appearing in the upper right corner of the display will not be correct.</li> <li>• Check the GNSS status to see the received satellites and their noise ratio.</li> </ul>
<b>No AIS transmission</b>	<ul style="list-style-type: none"> <li>• Make sure that MMSI number is correctly configured.</li> <li>• Make sure that silent mode is switched off.</li> <li>• Check that the available current is sufficient for transmission.</li> <li>• Check if the transponder might be operating in a regional area set with different operating mode.</li> </ul>
<b>AIS range seems too low</b>	<ul style="list-style-type: none"> <li>• Check VHF antenna and cable installation</li> <li>• Make sure the transponder is not operating in low power (1 W) mode.</li> </ul>
<b>No AIS targets on radar view and target list</b>	<ul style="list-style-type: none"> <li>• Check if VHF antenna, cabling and connector installations are damaged.</li> </ul>
<b>Sensor or Data ports not response</b>	<ul style="list-style-type: none"> <li>• Check that wiring polarity is not switched</li> <li>• Check that the transponder and the connected sensor have the same baud rate</li> </ul>

## 5.1 Troubleshooting with alarm messages

The M6 is monitoring itself constantly for failures or other important parameters with the built-in integrity test (BIIT). In case an abnormal operation is detected in one or more of the following conditions, an alert will be triggered and displayed on the screen, and the transponder will react as described in the following table.

Description text	BIIT ID	Reaction of the system (transponder)
<p><b>AIS: Tx malfunction</b>            The M6 has a built-in lock detector (high active) to monitor the local oscillator (PLL circuit) of the transmitter. If the operation of PLL circuit becomes abnormal, a logic low (Tx malfunction) will be sent from the lock detector to notify the system. At the same time, system will output an BIIT ID 001 alert at the related PI port.</p>	001	Stop transmission
<p><b>AIS: Antenna VSWR exceeds limit</b>            The M6 has a built-in RF output power detector to monitor the VSWR (Voltage Standing Wave Ratio) of the VHF antenna port. If the antenna VSWR exceeds a given limit, an alarm will be generated. If the VSWR goes below the defined threshold, the alarm is cleared.</p>	002	Continue operation
<p><b>AIS: Rx channel 1 malfunction</b>            The M6 has 3 built-in lock detectors (high active) to monitor each local oscillator (PLL circuit) of receiver channel 1, channel 2, and channel 70 respectively. If the operation of PLL circuit becomes abnormal, a logic low level will be sent from the lock detector to notify the system. At the same time, the system will output BIIT ID 003, BIIT ID 004 or BIIT ID 005 alert to indicate the CH1 or CH2 or CH70 RX malfunction respectively.</p>	003	Stop transmission on affected channel
<p><b>AIS: Rx channel 2 malfunction</b></p>	004	Stop transmission on affected channel
<p><b>AIS: Rx channel 70 malfunction</b></p>	005	Continue operation
<p><b>AIS: general failure</b></p>	006	Stop transmission
<p><b>AIS: UTC sync invalid</b></p>	007	Continue

This alarm is triggered when the transponder lost UTC direct synchronization or cannot synchronize from the internal GPS receiver.		operation using indirect or semaphore synchronization
<b>AIS: MKD connection lost</b> This alarm is active if the communication between the control unit and the display in the transponder does not work.	008	Continue operation
<b>AIS: internal / external GNSS position mismatch</b> This alarm is active if the difference between the internal and external GNSS position is more than 100m for more than 1 hour.	009	Continue operation
<b>AIS: NavStatus incorrect</b> For example, if the navigational status is set to "At Anchor" but the ship is moving faster than 3 knots, this alarm will become active.	010	Continue operation
<b>Heading sensor offset</b> This alarm is active when SOG is greater than 5kn and the difference between COG and HDT is greater than 45° for 5 min.	011	Continue operation
<b>AIS: active AIS SART</b> This alarm is active when the transponder receives an AIS SART position report.	014	Continue operation
<b>AIS: external EPFS lost</b> This alarm is active if the position from the external Electronic Position Fixing System is invalid.	025	Continue operation
<b>AIS: no sensor position in use</b> This alarm is active if there is no valid position from any sensor is available.	026	Continue operation
<b>AIS: no valid SOG information</b> This alarm is active if the transponder does not have a valid SOG from any sensor	029	Continue operation using default data
<b>AIS: no valid COG information</b> This alarm is active if the transponder does not have a valid COG from any sensor	030	Continue operation using default data
<b>AIS: Heading lost/invalid</b> This alarm is active if either the heading info from external sensor is lost or if the heading is undefined.	032	Continue operation using default data
<b>AIS: no valid ROT information</b> This alarm is active if ROT is undefined or if no valid ROT info is available.	035	Continue operation using default data

# Appendix A: Technical Information - Data Interface

## A.1 AIS Interface Overview

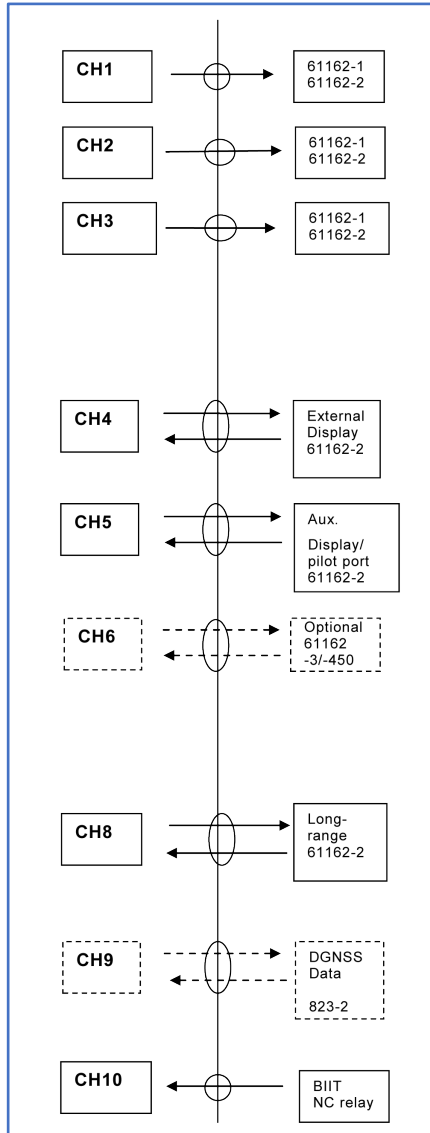

Figure A1 AIS Interface Overview

## A.2 M6 Data Interface (IEC 61162-2)

The M6 Class A AIS Transponder provides 2 types of IEC 61162-2 data interfaces for user applications. The first interface type includes 3 input-only sensor data ports and the second interface type includes 4 bidirectional input/output ports. Data port for each interface type will be described in the following section.

### A.2.1 Sensor Data Input Ports

The schematic of input-only sensor data port is shown in Figure A1. The schematic includes an isolated half duplex RS-485 transceiver IC which is used as the main component to receive external data. The transceiver IC is isolated from external input. To avoid signal reflection, the transceiver IC has an optional built-in 120 Ω loop termination, which is selectable by the dip-switch on the junction box and the switch should be set to on position when connecting external data source with long cable. All sensor data-input ports are isolated from one another and are also isolated from internal power supply. The input impedance on A/B wires is greater than 12 KΩ and the levels on the A/B wires are defined in the following:

- Logic low input:  $A-B < -0.2 \text{ V}$
- Logic high input:  $A-B > -0.02 \text{ V}$

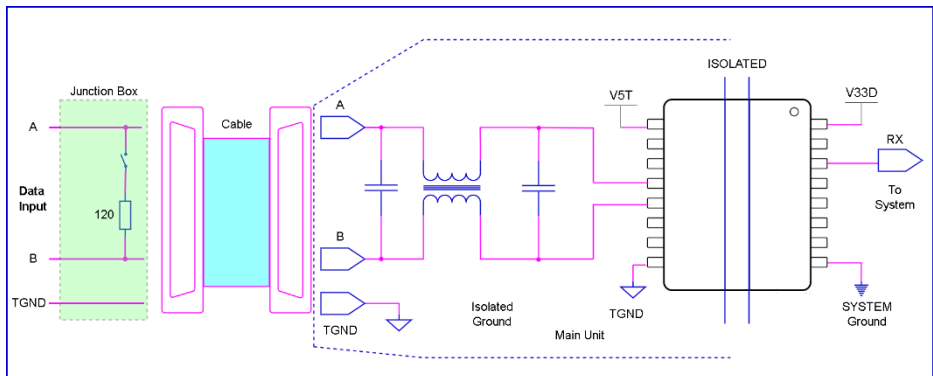

**Figure A2 Schematic of sensor data input port.**

## A.2.2 Bidirectional Data Ports

The schematic of bidirectional data port is shown in Figure A2. The schematics includes an isolated full duplex RS-485 transceiver IC which is used as the main component to handle both data input and output from external data source. The transceiver IC is isolated from external input. To avoid signal reflection, the transceiver IC has an optional built-in 120  $\Omega$  loop termination, which is selectable by the dip-switch on the junction box and the switch should be set to on position when connecting external data source with long cable. All bidirectional data ports are isolated from one another and are also isolated from internal power supply. The transceiver internal power supply is fully isolated from the external power supply.

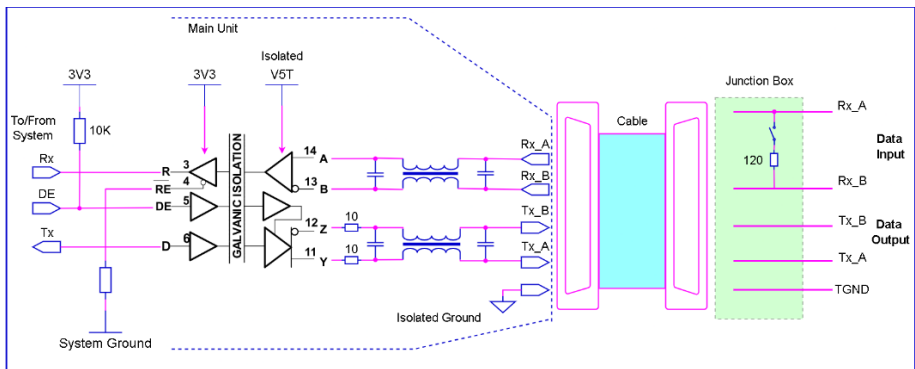

**Figure A3 Schematic of bidirectional data port.**

The output driver capability of bidirectional data port can provide a maximum of 60 mA, and the minimum differential output swing under 100  $\Omega$  load can be 2.3 V.

### A.2.3 A and B Signal Lines

Refer to sections A.1.1 and A.1.2.

### A.2.4 Output Driver

The output driver capability of bi-direction data port can provide maximum 60 mA, and the minimum differential output swing under 100  $\Omega$  load can be 2.3 V.

### A.2.5 Input Load

Refer to sections A.1.1 and A.1.2.

### A.2.6 Hardware Input/Output Circuit

Refer to sections A.1.1 and A.1.2.

## A.3 Supported IEC 61162 Data Sentences

<i>Data Port</i>	<i>Input Sentences</i>	<i>Output Sentences</i>
<b>Sensor 1 Sensor 2 Sensor 3 DGPS</b>	DTM, GBS, GGA, GLL, GNS, GSA, GSV, HDT, RMC, ROT, THS, VBW, VHW, VTG	N/A
<b>External Display Pilot</b>	ABM, ACA, ACN, ACK, AIQ, AIR, BBM, EPV, LRF, LRI, SSA, SSD, VSD	ABK, ACA, ACS, ALC, ALF, ALR, ARC, LR1, LR2, LR3, LRF, NAK, TXT, VDM, VDO, VER  For query(AIQ): ACA, EPV, SSD, TRL, TXT, VER, VSD
<b>Long Range</b>	LRF, LRI	LR1, LR2, LR3, LRF

### Sentence Output Interval:

<b>Sentence</b>	<b>Interval</b>
VDO	Once a second
ALR, ALC, ALF (active)	Once every thirty seconds
ALR (inactive)	Once every sixty seconds

## A.4 Interpretation of Input Sentences

### A.4.1 ABM – AIS Addressed Binary and Safety Related Message

This sentence supports ITU-R M.1371 Messages 6, 12, 25, 26 and provides an external application with a means to exchange data via an AIS transponder.

<b>!-ABM,x,x,x,xxxxxxxxx,x,xx,s—s,x*hh&lt;CR&gt;&lt;LF&gt;</b>			
<b>Field No.</b>	<b>Format</b>	<b>Description</b>	<b>Remark</b>
1	x	Total number of sentences needed to transfer the message	
2	x	Sentence number	
3	x	Sequential message identifier	
4	xxxxxxx xx	The MMSI of the destination AIS unit for the ITU-R M.1371 message	
5	x	AIS channel for broadcast of the radio	



		message	
6	xx	ITU-R M.1371 message ID	
7	s—s	Encapsulated data	
8	x	Number of fill-bits	

#### A.4.2 ACA – AIS Channel Assignment Message

An AIS device can receive regional channel management information.

\$-- ACA,x,IIII.II,a,yyyyy.yy,a,IIII.II,a,yyyyy.yy,a,x,xxxx,x,xxxx,x,x,a,x,hhmmss.ss*hh< CR><LF>			
Field No.	Format	Description	Remark
1	x	Sequence Number	
2	IIII.II,a	Region northeast corner latitude – N/S	
3	yyyyy.yy,a	Region northeast corner longitude – E/W	
4	IIII.II,a	Region southwest corner latitude – N/S	
5	yyyyy.yy,a	Region southwest corner longitude – E/W	
6	x	Transition zone size	
7	xxxx	Channel A	
8	x	Channel A bandwidth	
9	xxxx	Channel B	
10	x	Channel B bandwidth	
11	x	Tx/Rx mode control	
12	x	Power level control	
13	a	Information source	
14	x	In-use flag	
15	hhmmss.ss	Time of “in use” change	

### A.4.3 ACK – Acknowledge Alarm

This sentence is used to acknowledge an alarm condition reported by a device.

\$--ACK,xxx*hh<CR><LF>			
Field No.	Format	Description	Remark
1	xxx	Unique alarm number (identifier) at alarm source	

### A.4.4 AIQ - Query Sentence

This sentence is used to inquire AIS sentence information.

\$--AIQ,c—c*hh<CR><LF>			
Field No.	Format	Description	Remark
1	c—c	Support query sentence of ACA, EPV, SSD, TRL, TXT, VER, VSD	

### A.4.5 AIR – AIS Interrogation Request

This sentence supports ITU-R M.1371 messages 15 and 10. It provides an external application with the means to initiate requests for specific ITU-R M.1371 messages from AIS unit.

\$--AIR,xxxxxxxxxx,x.x,x,x.x,x,xxxxxxxxxx,x.x,x*hh<CR><LF>			
Field No.	Format	Description	Remark
1	xxxxxxxxx x	MMSI of interrogated station 1	
2	x.x	ITU-R M.1371 message requested from station-1	
3	x	Message sub-section	ignored
4	x.x	Number of second message requested from station-1	
5	x	Message sub-section	ignored
6	xxxxxxxxx x	MMSI of interrogated station-2	
7	x.x	Number of messages requested from station-2	
8	x	Message sub-section	ignored

### A.4.6 **BBM – AIS Broadcast Binary Message**

This sentence supports generation of ITU-R M.1371 binary messages 8, 14, 25, and 26. This provides the application with a means to broadcast data, as defined by the application only.

!--BBM,x,x,x,x,x,x,s—s,x*hh<CR><LF>			
Field No.	Format	Description	Remark
1	x	Total number of sentences needed to transfer the message	
2	x	Sentence number	
3	x	Sequential message identifier	
4	x	AIS channel for broadcast of the radio message	
5	x.x	ITU-R M.1371 Message ID	
6	s—s	Encapsulated data	
7	x	Number of fill-bits	

### A.4.7 **DTM – Datum Reference**

Local geodetic datum and datum offsets from a reference datum.

\$--DTM,ccc,a,x.x,a,x.x,a, x.x,ccc*hh<CR><LF>			
Field No.	Format	Description	Remark
1	ccc	Local datum	
2	a	Local datum subdivision code	ignored
3	x.x, a	Lat offset, min, N/S	ignored
4	x.x, a	Lon offset, min, E/W	ignored
5	x.x	Altitude offset, m	ignored
6	ccc	Reference datum	

#### A.4.8 EPV – Command or Report Equipment Property Value

\$--EPV,a,cc,c--c,x.x,c--c*hh<CR><LF>			
Field No.	Format	Description	Remark
1	a	Sentence status flag	
2	cc	Destination equipment type	
3	c--c	Unique identifier	
4	x.x	Property identifier	
5	c--c	Value of property to be set	

#### A.4.9 GBS – GNSS Satellite Fault Detection

This sentence is used to support receiver autonomous integrity monitoring (RAIM).

\$--GBS, hhmss.ss, x.x, x.x, x.x, xx, x.x, x.x, x.x *hh <CR><LF>			
Field No.	Format	Description	Remark
1	hhmss.ss	UTC time of the GGA or GNS fix associated with this sentence	
2	x.x	Expected error in latitude	
3	x.x	Expected error in longitude	
4	x.x	Expected error in altitude	ignored
5	xx	ID number of most likely failed satellite	ignored
6	x.x	Probability of missed detection for most likely failed satellite	ignored
7	x.x	Estimate of bias on most likely failed satellite	ignored
8	x.x	Standard deviation of bias estimate	ignored

#### A.4.10 GGA – Global positioning system (GPS) fix data

Time, position and fix-related data for a GPS receiver.

\$--GGA, hhmmss.ss, llll.ll, a, yyyyy.yy, a, x, xx, x.x, x.x, M, x.x, M, x.x, xxxx*hh<CR><LF>			
Field No.	Format	Description	Remark
1	hhmmss.ss	UTC of position	
2	llll.ll,a	Latitude N/S	
3	yyyyy.yy,a	Longitude E/W	
4	x	GPS quality indicator	ignored
5	xx	Number of satellites in use, 00-12, may be different from the number in view	ignored
6	x.x	Horizontal dilution of precision	ignored
7	x.x	Antenna altitude above/below mean sea level (geoid)	ignored
8	M	Units of antenna altitude, m	ignored
9	x.x	Geoidal separation	ignored
10	M	Units of geoidal separation,m	ignored
11	x.x	Age of differential GPS data	ignored
12	xxxx	Differential reference station ID, 0000-1023	ignored

#### A.4.11 GLL – Geographic Position – Latitude/Longitude

Latitude and longitude of vessel position, time of position fix and status.

\$--GLL, llll.ll, a, yyyyy.yy, a, hhmmss.ss, A, a *hh<CR><LF>			
Field No.	Format	Description	Remark
1	llll.ll, a	Latitude, N/S	
2	yyyyy.yy, a	Longitude, E/W	
3	hhmmss.ss	UTC of position	
4	A	Status, A=data valid V=data invalid	
5	a	Mode indicator	

#### A.4.12 GNS – GNSS Fix Data

Fix data for single or combined satellite navigation systems (GNSS). This sentence provides fix data for GPS, GLONASS, possible future satellite systems and systems combining these.

\$-- GNS, hhhmss.ss, llll.ll, a, yyyyyy.yy, a, c--c,xx,x.x,x.x,x.x,x.x,x.x,x.x,a *hh<CR><LF>			
Field No.	Format	Description	Remark
1	hhmmss.ss	UTC of position	
2	llll.ll, a	Latitude, N/S	
3	yyyyy.yy, a	Longitude, E/W	
4	c--c	Mode indicator	
5	xx	Total number of satellites in use	ignored
6	x.x	HDOP	ignored
7	x.x	Antenna altitude, m, re:mean-sea-level (geoid)	ignored
8	x.x	Geoidal separation, m	ignored
9	x.x	Age of differential data	ignored
10	x.x	Differential reference station ID	ignored
11	a	Nacigational status indicator	

#### A.4.13 GSA – GNSS DOP and Active Satellites

GNSS receiver operating mode, satellites used in the navigation solution reported by the GGA or GNS sentences, and DOP values. If only GPS, GLONASS, etc. are used for the reported position solution, the talker ID is GP, GL, etc. and the DOP values pertain to the individual system.

\$--GSA, a, x, xx,xx,xx,xx,xx,xx,xx,xx,xx,xx,xx,xx,x.x,x.x,x.x*x*hh<CR><LF>			
Field No.	Format	Description	Remark
1	a	Mode: M = manual, forced to operate in 2D or 3D mode A = automatic, allowed to automatically switch 2D/3D	
2	x	Mode: 1 = fix not available, 2 = 2D, 3 = 3D	

3	XX,XX,XX,XX, XX,XX,XX,XX, XX,XX,XX,XX	ID numbers of satellites used in solution	
4	x.x	PDOP	
5	x.x	HDOP	
6	x.x	VDOP	

#### A.4.14 HDT – Heading True

Actual vessel heading in degrees true produced by any device or system producing true heading.

\$--HDT, x.x, T*hh<CR><LF>			
Field No.	Format	Description	Remark
1	x.x, T	Heading, degrees true	

#### A.4.15 LRF – AIS Long-Range Function

This sentence is used in both long-range interrogation requests and long-range interrogation replies. The LRF-sentence is the second sentence of the long-range interrogation request pair, LRI and LRF (see the LRI-sentence).

\$--LRF,x,xxxxxxxx,c—c,c—c—c*hh<CR><LF>			
Field No.	Format	Description	Remark
1	x	Sequence number	
2	xxxxxxxx	MMSI of requestor	
3	c—c	Name of requestor	
4	c—c	Function request	
5	c—c	Function reply status	

#### A.4.16 LRI – AIS Long-Range Interrogation

The long-range interrogation of the AIS unit is accomplished through the use of two sentences. The pair of interrogation sentence formatters, a LRI sentence followed by a LRF sentence, provides the information needed by a universal AIS unit to determine if it should construct and provide the reply sentences (LRF, LR1, LR2, and LR3).

\$--LRI,x,a,xxxxxxxx,xxxxxxxx,IIII.II,a,yyyyy.yy,a,IIII.II,a,yyyyy.yy,a*hh<CR><LF>			
Field No.	Format	Description	Remark
1	x	Sequence number	
2	a	Control flag	
3	xxxxxxxx	MMSI of requestor	
4	xxxxxxxx	MMSI of destination	
5	IIII.II,a	Latitude – N/S	
6	yyyyy.yy,a	Longitude – E/W	
7	IIII.II,a	Latitude – N/S	
8	yyyyy.yy,a	Longitude – E/W	

#### A.4.17 RMC – Recommended Minimum Specific GNSS Data

Time, date, position, course and speed data provided by a GNSS navigation receiver.

\$--RMC, hhmmss.ss, A, IIII.II,a, yyyyy.yy, a, x.x, x.x, xxxxxx, x.x,a, a, a*hh<CR><LF>			
Field No.	Format	Description	Remark
1	hhmmss.ss	UTC of position fix	
2	A	Status	
3	IIII.II,a	Latitude, N/S	
4	yyyyy.yy, a	Longitude, E/W	
5	x.x	Speed over ground, knots	
6	x.x	Course over ground, degrees true	
7	xxxxxx	Date: dd/mm/yy	
8	x.x,a	Magnetic variation, degrees, E/W	
9	a	Mode indicator	
10	a	Navigational status	



#### A.4.18 ROT – Rate of Turn

Rate of turn and direction of turn.

\$--ROT, x.x, A*hh<CR><LF>			
Field No.	Format	Description	Remark
1	x.x	Rate of turn, °/min	
2	A	Status: A = data valid, V = data invalid	

#### A.4.19 SSA –Sender Signature Authentication

This sentence can be used both for authentication of sender and for authentication of untampered content. For this purpose, the sentence has to be applied before the protected sentence (for example EPV, SSD).

Other sentences shall not be interleaved between the sender signature authentication sentence and protected sentence, and the time between the SSA and the protected sentence should be limited. The sender signature authentication protected sentence pair shall be sent without unnecessary delay between sentences, and the time interval between the sentences shall not exceed 2 s. Note that any of the sentences may be lost and timed out.

\$--SSA,ccc,c,h—h,aa*hh<CR><LF>			
Field No.	Format	Description	Remark
1	ccc	The following sentence formatter that should be protected (for example EPV or SSD).	
2	c	Type of method to calculate signature: 1: MD5	
3	h--h	Hexadecimal representation of the signature, for example 32 hexacodes for MD5.	

#### A.4.20 SSD – AIS Ship Static Data

This sentence is used to enter static parameters into a shipboard AIS unit. The parameters in this sentence support a number of the ITU-R M.1371 Messages.

\$--SSD,c—c,c—c,xxx,xxx,xx,xx,c,aa*hh<CR><LF>			
Field No.	Format	Description	Remark
1	c—c	Ship's call sign	
2	c—c	Ship's name	
3	xxx	Pos. ref., point dist. "A,"	
4	xxx	Pos. ref., point dist. "B,"	
5	xx	Pos. ref., point dist. "C,"	
6	xx	Pos. ref., point dist. "D,"	
7	c	DTE indicator flag	
8	aa	Source identifier	

#### A.4.21 THS – True Heading and Status

Actual vessel heading in degrees true produced by any device or system producing true heading. This sentence includes a "mode indicator" field providing critical safety related information about the heading data, and replaces the deprecated HDT sentence.

\$--THS,x.x,a*hh<CR><LF>			
Field No.	Format	Description	Remark
1	x.x	Heading, degrees true	
2	a	Mode indicator	

#### A.4.22 VBW – Dual Ground/Water Speed

Water-referenced and ground-referenced speed data.

§--VBW, x.x, x.x, A, x.x, x.x, A, x.x, A, x.x, A*hh<CR><LF>			
Field No.	Format	Description	Remark
1	x.x	Longitudinal water speed, knots	ignored
2	x.x	Transverse water speed, knots	ignored
3	A	Status : water speed, A = data valid, V = data invalid	ignored
4	x.x	Longitudinal ground speed, knots	
5	x.x	Transverse ground speed, knots	
6	A	Status, ground speed, A = data valid, V = data invalid	
7	x.x	Stern transverse water speed, knots	ignored
8	A	Status : stern water speed, A = data valid, V = data invalid	ignored
9	x.x	Stern transverse ground speed, knots	ignored
10	A	Status : stern ground speed, A = data valid, V = data invalid	ignored

#### A.4.23 VHW – Water speed and heading

The compass heading to which the vessel points and the speed of the vessel relative to the water.

§--VHW, x.x, T, x.x, M, x.x, N, x.x, K*hh<CR><LF>			
Field No.	Format	Description	Remark
1	x.x, T	Heading, degrees true	
2	x.x, M	Heading, degrees magnetic	Ignored
3	x.x, N	Speed, knots	Ignored
4	x.x, K	Speed, km/h	Ignored

#### A.4.24 VSD – AIS Voyage Static Data

This sentence is used to enter information about a ship's transit that remains relatively static during the voyage.

\$--VSD,x.x,x.x,x.x,c—c,hhmmss.ss,xx,xx,x.x,x.x*hh<CR><LF>			
Field No.	Format	Description	Remark
1	x.x	Type of ship and cargo category	
2	x.x	Maximum present static draught	
3	x.x	Persons on-board	
4	c—c	Destination	
5	hhmmss.ss	Estimated UTC of arrival at destination	
6	xx	Estimated day of arrival at destination	
7	xx	Estimated month of arrival at destination	
8	x.x	Navigational status	
9	x.x	Regional application flags	

#### A.4.25 VTG – Course Over Ground and Ground Speed

The actual course and speed relative to the ground.

\$--VTG, x.x, T, x.x, M, x.x, N, x.x, K,a*hh<CR><LF>			
Field No.	Format	Description	Remark
1	x.x, T	Course over ground, degrees true	
2	x.x, M	Course over ground, degrees magnetic	ignored
3	x.x, N	Speed over ground, knots	
4	x.x, K	Speed over ground, km/h	ignored
5	a	Mode indicator	

## A.4.26 PAMC, DBG – Proprietary Sentences, Debug

The proprietary sentences are additional sentences only applicable to this product. Its main usage is for enabling testing mode and parameter settings.

This sentence is used for configuration. It commands unit with given parameters.

\$PAMC,C,c-c,x,x,x,x,x,x,x,x*hh<CR><LF>			
Field No.	Format	Description	Remark
1	C	Command : “C”	
2	c-c	Function type. For example, DBG.	
3	x	Parameter Id 1 , 0-998	
4	x	Parameter value 1 , 0- 1000000000	
5	x	Parameter Id 2 , 0-998	
6	x	Parameter value 2, 0- 1000000000	
7	x	Parameter Id 3 , 0-998	
8	x	Parameter value 3, 0- 1000000000	
9	x	Parameter Id 4 , 0-998	
10	x	Parameter value 4, 0- 1000000000	

This sentence is used for retrieving responses.

\$PAMC,R,c-c,x,x,x,x,x,x,x,x*hh<CR><LF>			
Field No.	Format	Description	Remark
1	R	Response : “R”	
2	c-c	Function type. For example, DBG.	
3	x	Parameter Id 1 , 0-998	
4	x	Parameter value 1 , 0- 1000000000	
5	x	Parameter Id 2 , 0-998	
6	x	Parameter value 2, 0- 1000000000	
7	x	Parameter Id 3 , 0-998	
8	x	Parameter value 3, 0- 1000000000	
9	x	Parameter Id 4 , 0-998	
10	x	Parameter value 4, 0- 1000000000	

#### A.4.27 PAMC, DSC – Proprietary Sentences, Digital selective calling

When AIS transponder receives DCS messages, this sentence is used to output DSC pattern.

\$PAMC,R,DSC,c-c*hh<CR><LF>			
Field No.	Format	Description	Remark
1	c-c	DSC pattern	

#### A.4.28 ACN – Alert command

This sentence is used for acknowledge, silence, responsibility transfer and to request repeat of alert details in case the reception process has detected, based on ALC, that ALF has been missed.

\$--ACN,hhmmss.ss,aaa,x.x,x.x,c,a*hh <CR><LF>			
Field No.	Format	Description	Remark
1	hhmmss.ss	Time	
2	aaa	Manufacturer mnemonic code	
3	x.x	Alert Identifier	
4	x.x	Alert Instance, 1 to 999999	
5	c	Alert command, A, Q, O or S	
6	a	Sentence status flag	

## A.5 Interpretation of Output Sentences

### A.5.1 ABK – AIS Addressed and Binary Broadcast Acknowledgement

The ABK-sentence is generated when a transaction, initiated by reception of an ABM, AIR, or BBM sentence, is completed or terminated.

\$--ABK,xxxxxxxx,x,x,x,x,x*hh<CR><LF>			
Field No.	Format	Description	Remark
1	xxxxxxxx	MMSI of the addressed AIS unit	
2	x	AIS channel of reception	
3	x.x	ITU-R M.1371Message ID	
4	x	Message sequence number	
5	x	Type of acknowledgement	

### A.5.2 ACA – AIS Channel Assignment Message

An AIS device can receive regional channel management information

\$- ACA,x,IIII.II,a,yyyyy.yy,a,IIII.II,a,yyyyy.yy,a,x,xxxx,x,xxxx,x,x,a,x,hhmss.ss*hh<CR><LF>			
Field No.	Format	Description	Remark
1	x	Sequence Number	
2	IIII.II,a	Region northeast corner latitude – N/S	
3	yyyyy.yy,a	Region northeast corner longitude – E/W	
4	IIII.II,a	Region southwest corner latitude – N/S	
5	yyyyy.yy,a	Region southwest corner longitude – E/W	
6	x	Transition zone size	
7	xxxx	Channel A	
8	x	Channel A bandwidth	
9	xxxx	Channel B	
10	x	Channel B bandwidth	
11	x	Tx/Rx mode control	
12	x	Power level control	
13	a	Information source	
14	x	In-use flag	
15	hhmss.ss	Time of “in use” change	

### A.5.3 ALR – Set Alarm State

Local alarm condition and status. This sentence is used to report an alarm condition on a device and its current state of acknowledgement.

\$--ALR,hhmmss.ss,xxx,A, A,c--c*hh<CR><LF>			
Field No.	Format	Description	Remark
1	hhmmss.ss	Time of alarm condition change, UTC	
2	xxx	Unique alarm number (identifier) at alarm source	
3	A	Alarm condition, A = threshold exceeded, V = not exceeded	
4	A	Alarm's acknowledge state, A = acknowledged, V = unacknowledged	
5	c--c	Alarm's description text	

### A.5.4 EPV – Command or Report Equipment Property Value

\$--EPV,a,cc,c--c,x.x,c--c*hh<CR><LF>			
Field No.	Format	Description	Remark
1	a	Sentence status flag	
2	cc	Destination equipment type	
3	c--c	Unique identifier	
4	x.x	Property identifier	
5	c--c	Value of property to be set	

### A.5.5 LR1 – AIS Long-Range Reply Sentence 1

The LR1 sentence identifies the destination for the reply and contains the information items requested by the "A" function identification character (see the LRF sentence).

\$--LR1,x,xxxxxxxx,xxxxxxxx,c--c,c--c,xxxxxxxx*hh<CR><LF>			
Field No.	Format	Description	Remark
1	x	Sequence number	
2	xxxxxxxx	MMSI of responder	
3	xxxxxxxx	MMSI of requestor	
4	c--c	Ship's name, 1 to 20 characters	
5	c--c	Call sign, 1 to 7 characters	
6	xxxxxxxx	IMO number, 9-digit number	



### A.5.6 LR2 – AIS Long-Range Reply Sentence 2

The LR2-sentence contains the information items requested by the “B, C, E and F” function identification characters, (see the LRF sentence)

\$-- LR2,x,xxxxxxxx,xxxxxxxx,hhmmss.ss,lll.l,a,yyyy.yy,a,x.x,T,x.x,N*hh<CR><LF>			
Field No.	Format	Description	Remark
1	x	Sequence number	
2	xxxxxxxx	MMSI of responder	
3	xxxxxxxx	Date: ddmmyyyy, 8 digits	
4	hhmmss.ss	UTC time of position	
5	lll.l,a	Latitude – N/S	
6	yyyy.yy,a	Longitude, E/W	
7	x.x,T	Course over ground, degrees, true	
8	x.x,N	Speed over ground, knots	

### A.5.7 LR3 – AIS Long-Range Reply Sentence 3

The LR3 sentence contains the information items requested by the “I, O, P, U and W” function identification character (see the LRF sentence).

\$--LR3,x,xxxxxxxx,c—c,xxxxxx,hhmmss.ss,x.x,x.x,x.x,x.x,x.x,x.x*x*hh<CR><LF>			
Field No.	Format	Description	Remark
1	x	Sequence number	
2	xxxxxxxx	MMSI of responder	
3	c—c	Voyage destination, 1 to 20 chars	
4	xxxxxx	ETA date: ddmmyy	
5	hhmmss.ss	ETA time	
6	x.x	Draught	
7	x.x	Ship/cargo	
8	x.x	Ship length	
9	x.x	Ship breadth	
10	x.x	Ship type	
11	x.x	Persons, 0 to 8191	

### A.5.8 LRF – AIS Long-Range Function

This sentence is used in both long-range interrogation requests and long-range interrogation replies. The LRF-sentence is the second sentence of the long-range interrogation request pair, LRI and LRF (see the LRI-sentence).

\$--LRF,x,xxxxxxxx,c—c,c—c,c—c*hh<CR><LF>			
Field No.	Format	Description	Remark
1	x	Sequence number	
2	xxxxxxxx	MMSI of requestor	
3	c—c	Name of requestor	
4	c—c	Function request	
5	c—c	Function reply status	

### A.5.9 TRL –AIS transmitter-non-functioning log

This sentence is specific to AIS class A stations. It is intended to support the retrieval of the AIS non-functioning log information.

\$--TRL,x.x,x.x,x,xxxxxxxx,hhmmss.ss,xxxxxxxx,hhmmss.ss,x*hh<CR><LF>			
Field No.	Format	Description	Remark
1	x.x	Total number of log entries	
2	x.x	Log entry number	
3	x	Sequential message identifier	
4	xxxxxxxx	Switch off date	
5	hhmmss.ss	Switch off UTC time	
6	xxxxxxxx	Switch on date	
7	hhmmss.ss	Switch on UTC time	
8	x	Reason code 1 = power off; 2 = silent mode; 3 = transmission switched off by channel management command; 4 = equipment malfunction; 5 = invalid configuration;	

### A.5.10 TXT – Text Transmission

For the transmission of short text messages. Longer text messages may be transmitted by using multiple sentences.

\$--TXT,xx,xx,xx,c--c*hh<CR><LF>			
Field No.	Format	Description	Remark
1	xx	Total number of sentences	
2	xx	Sentence number	
3	xx	Text identifier	
4	c--c	Text message	

### A.5.11 VDM – AIS VHF Data-Link Message

This sentence is used to transfer the entire contents of a received AIS message packet, as defined in ITU-R M.1371 and as received on the VHF Data Link (VDL), using the “six-bit” field type.

!--VDM,x,x,x,a,s—s,x*hh<CR><LF>			
Field No.	Format	Description	Remark
1	x	Total number of sentences needed to transfer the message	
2	x	Sentence number	
3	x	Sequential message identifier	
4	a	AIS channel	
5	s—s	Encapsulated ITU-R M.1371 radio message	
6	x	Number of fill-bits	

### A.5.12 VDO – AIS VHF Data-Link Own-Vessel Report

This sentence is used to transfer the entire contents of an AIS unit’s broadcast message packet, as defined in ITU-R M.1371 and as sent out by the AIS unit over the VHF data link (VDL) using the “six-bit” field type.

!--VDO,x,x,x,a,s—s,x*hh<CR><LF>			
Field No.	Format	Description	Remark
1	x	Total number of sentences needed to transfer the message	
2	x	Sentence number	
3	x	Sequential message identifier	
4	a	AIS channel	
5	s—s	Encapsulated ITU-R M.1371 radio message	
6	x	Number of fill-bits	

### A.5.13 ALC – Cyclic alert list

The purpose of this sentence is to satisfy the needs for a safe and consistent data distribution with a minimum of data traffic. Each change on an alert’s data leads to an incremented Revision counter. So an alert processing device only needs to check the alert entries in the ALC messages to ensure that no ALF message has been lost.

\$--ALC,xx,xx,xx,x.x,aaa,x.x,x.x,x.x,.....,aaa,x.x,x.x,x.x*hh <CR><LF>			
Field No.	Format	Description	Remark
1	xx	Total number of sentences for this message, 01 to 99	
2	xx	Sentence number, 01 to 99 1	
3	xx	Sequential message identifier, 00 to 99	
4	x.x	Number of alert entries	
5	aaa	Manufacturer mnemonic code	
6	x.x	Alert identifier	
7	x.x	Alert instance (BIIT ID)	
8	x.x	Revision counter	
9	.....	Additional Alert entries	
10	aaa,x.x,x.x,x.x	Alert entry n	

### A.5.14 ALF – Alert sentence

This sentence is used to report an alert condition and the alert state of a device. An ALF message shall be published for an alert each time the alert information in this sentence changes and on alert request

\$--ALF,x,x,x,hhmmss.ss,a,a,a,aaa,x.x,x.x,x.x,c---c*hh <CR><LF>			
Field No.	Format	Description	Remark
1	x	Total number of ALF sentences for this message, 1 to 2	
2	x	Sentence number, 1 to 2	
3	x	Sequential message identifier, 0 to 9	
4	hhmmss.ss	Time of last change	
5	a	Alert category, A, B or C	
6	a	Alert priority, E, A, W or C	
7	a	Alert state, A, S, N, O, U or V	
8	aaa	Manufacturer mnemonic code	
9	x.x	Alert identifier	
10	x.x	Alert instance (BIIT ID), 1 to 999999	
11	x.x	Revision counter, 1 to 99	
12	x	Escalation counter, 0 to 9	
13	c---c	Alert text	

### A.5.15 ARC – Alert command refused

This sentence is used for which it is illegal to accept acknowledge or responsibility transfer, e.g. not enough information for decision support available or the source of acknowledgement is not acceptable.

\$--ARC,hhmmss.ss,aaa,x.x,x.x,c*hh <CR><LF>			
Field No.	Format	Description	Remark
1	hhmmss.ss	Time	
2	aaa	Manufacturer mnemonic code	
3	x.x,	Alert identifier	
4	x.x,	Alert instance (BIIT ID), 1 to 999999	
5	c	Refused alert command, A, Q, O or S	

## Appendix B: M6 NMEA 2000 PGN Information

The following table is a list of the NMEA 2000 PGNs supported by the M6 unit.

OUTPUT	
PGN	Description
<b>59392</b>	ISO Acknowledgment
<b>59904</b>	ISO Request
<b>60160</b>	ISO Transport Protocol, Data Transfer
<b>60416</b>	ISO Transport Protocol, Connection Management
<b>60928</b>	ISO Address Claim
<b>126208</b>	NMEA – Acknowledge group function
<b>126464</b>	PGN List - Transmit PGN's group function
<b>126993</b>	Heartbeat
<b>126996</b>	Product Information
<b>126998</b>	Configuration Information
<b>129038</b>	AIS Class A Position Report
<b>129039</b>	AIS Class B Position Report
<b>129040</b>	AIS Class B Extended Position Report
<b>129041</b>	AIS Aids to Navigation (AtoN) Report
<b>129792</b>	AIS DGNSS Broadcast Binary Message
<b>129793</b>	AIS UTC and Date Report
<b>129794</b>	AIS Class A Static and Voyage Related Data
<b>129795</b>	AIS Addressed Binary Message
<b>129797</b>	AIS Binary Broadcast Message
<b>129798</b>	AIS SAR Aircraft Position Report
<b>129800</b>	AIS UTC/Date Inquiry
<b>129801</b>	AIS Addressed Safety Related Message
<b>129802</b>	AIS Safety Related Broadcast Message
<b>129803</b>	AIS Interrogation
<b>129804</b>	AIS Assignment Mode Command
<b>129805</b>	AIS Data Link Management Message
<b>129806</b>	AIS Channel Management

<b>129807</b>	AIS Group Assignment
<b>129809</b>	AIS Class B “CS” Static Data Report, Part A
<b>129810</b>	AIS Class B “CS” Static Data Report, Part B
<b>129811</b>	AIS Single Slot Binary Message
<b>129812</b>	AIS Multi Slot Binary Message
<b>129813</b>	AIS Long-Range Broadcast Message
<b>129816</b>	AIS Acknowledge

<b>INPUT</b>	
<b>PGN</b>	<b>Description</b>
<b>59392</b>	ISO Acknowledgment
<b>59904</b>	ISO Request
<b>60160</b>	ISO Transport Protocol, Data Transfer
<b>60416</b>	ISO Transport Protocol, Connection Management
<b>60928</b>	ISO Address Claim
<b>65240</b>	ISO Commanded Address
<b>126208</b>	NMEA – Request group function NMEA – Command group function

## Appendix C: Installation and Maintenance Record

The following installation record should be completed and retained on board the vessel for maintenance records.

Vessel Information			
Vessel Name		Flag State	
IMO Number		MMSI Number	
Owner/Company		Radio call sign	
Type of vessel		Gross tonnage	
Length	m	Beam	m

AIS Class A Transponder Information			
Transponder S/N		Pilot Plug S/N	
Junction Box S/N		GPS Ant. S/N	
Password			
Power supply	Voltage: V	Maximum output current: A	
Note			

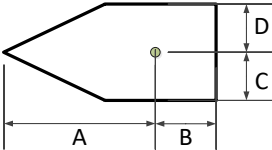
GPS/GNSS Antenna Location			
A= Distance to Bow	m	C= Dist. To Port-Side	m
B= Distance to Stern	m	D= Dist. To Starboard	m
			



<b>Connected Sensors and Devices</b>		
<b>Connected Port</b>	<b>Equipment</b>	<b>Model Number</b>
Sensor 1		
Sensor 2		
Sensor 3		
Ext Display Port		
Pilot Port		
Long Range Port		
DGNSS Data Port		
Other Device		

<b>Installer Information</b>		
<b>Company Name</b>		
<b>Technician's Name</b>		
<b>Telephone/Mobile No.</b>		
<b>Address</b>		
<b>Place</b>	<b>Date</b>	<b>Installer's Signature</b>

## **Appendix D: USCG Check List & Report**

For USA vessel owners, please visit the USCG website to download the voluntary checklist to assist the surveyor or owner in ensuring the ship's Automatic Identification System (AIS) in operation is properly operating as defined in 33 CFR §164, 47 CFR §80, and, Safety of Life at Sea Convention (SOLAS) Chapter V Regulation 18.9.

The USCG AIS Checklist is posted on line here:

[https://www.navcen.uscg.gov/sites/default/files/pdf/AIS/USCG AIS Inspection C  
hecklist19 10 01.pdf](https://www.navcen.uscg.gov/sites/default/files/pdf/AIS/USCG_AIS_Inspection_Checklist19_10_01.pdf)

## Software Revisions

The transponder is delivered with software version according to the following table which is to be filled in and maintained either by manufacturer, distributor, dealer, or installation company. When software update is done, the new software (firmware) version can be identified through MKD at MENU/DIAGNOSTICS/VERSION (please refer to section 2.9.5 in the Operator Manual). Each new software upgrade requires information recorded to reflect the change made.

Software Maintenance Record			
Software Version	By	Date	Change

## 6 DOCUMENT REVISIONS

Date	Rev/Issue	Changes
2024-02-21	1	Initial issue
2024-04-30	2	Graphics update
2024-09-05	3	Graphic and Typo Corrections
2024-09-11	4	UK Declaration of Conformity added.

**NOTE:**

**NetWave Systems B.V.**

Blauw-roodlaan 100,  
2718 SJ Zoetermeer

The Netherlands

Phone: +31 (0)881181500

Email: [info@seasofsolutions.com](mailto:info@seasofsolutions.com)

[www.seasofsolutions.com](http://www.seasofsolutions.com)