

kannad
marine



Kannad Marine Safelink

AIS SART

Safety notices



WARNING: An AIS SART is an emergency radio beacon.
Operate only in situations of imminent danger to life.



CAUTION: False alerts endanger lives and cause disruption to Search and Rescue services. Deliberate misuse of the AIS SART could result in penalty.



CAUTION: If the anti-tamper tab is broken, the SART is not compliant with SOLAS regulations and must be repaired or replaced.



CAUTION: Do not dismantle the AIS SART; it contains no user-serviceable parts.



CAUTION: Contains lithium batteries. Do not incinerate, puncture, deform, short-circuit or recharge.



CAUTION: Dispose of a used AIS SART in accordance with local waste disposal regulations. Refer to End of Life Statement.



CAUTION: Avoid using chemical solvents to clean the AIS SART as some solvents can damage the case material.



CAUTION: An AIS SART is a radio transmitter. Some administrations may require that the user holds a valid radio licence to cover its ownership and use.

Radio Frequency Exposure Warning



WARNING: The AIS SART emits low levels of radio frequency radiation; avoid handling the upper section antenna zone when activated.

Ownership details

Vessel Name:

Owner details:

Unique ID;

9	7	0							
---	---	---	--	--	--	--	--	--	--

Disclaimer

The information and illustrations contained in this publication are to the best of our knowledge correct at the time of going to print. We reserve the right to change specifications, equipment, installation and maintenance instructions without notice as part of our policy of continuous product development and improvement. No part of this publication may be reproduced, stored in a retrieval system or transmitted in any form, electronic or otherwise without permission in writing from Orolia Ltd. No liability can be accepted for any inaccuracies or omissions in the publication, although every care has been taken to make it as complete and accurate as possible.

IN EMERGENCY

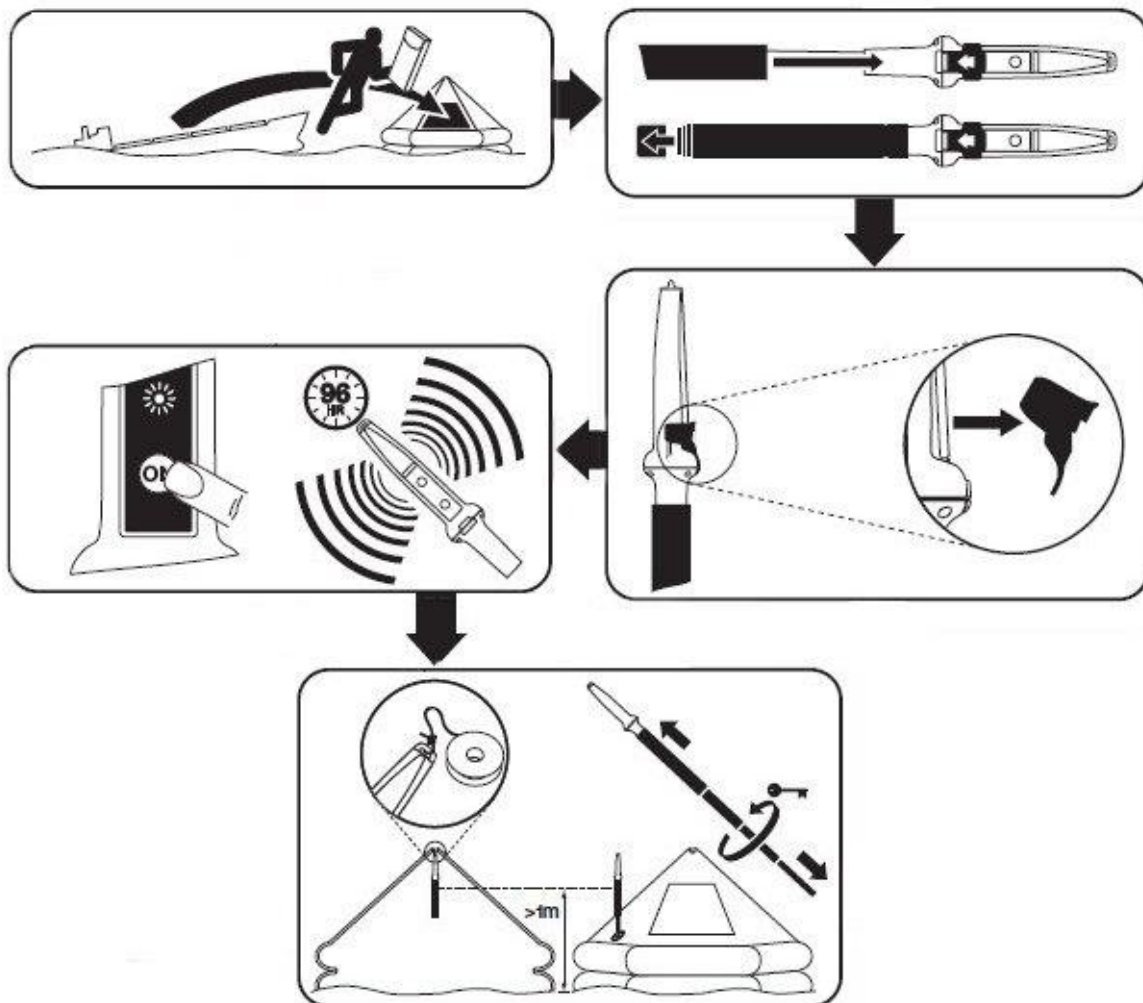

The AIS SART is a locating radio beacon for use only in emergency situations. False alerts endanger lives; help prevent them by understanding how to look after and correctly operate the AIS SART.

Introduction

Thank you for purchasing the AIS SART 'search and rescue locating device'. The AIS SART is designed to assist in survivor craft location during search and rescue operations.

The AIS SART is primarily intended for fitment by SOLAS vessels under carriage requirement rules. SOLAS fitting rules differ depending on type and size of vessel and liferaft. In general, at least one search and rescue locating device is carried on each side of every passenger and cargo ship over 500 gross tons. Smaller SOLAS classified vessels are required to carry at least one search and rescue locating device.

The AIS-SART is a portable device and should be stowed on board in a location where it can be easily and rapidly placed in any liferaft.

Product registration

Each AIS SART carries a unique serial number printed on the label on the yellow body. It is recommended that a record of the AIS SARTs' unique identifier number should be kept by the vessels management organisation.

Overview

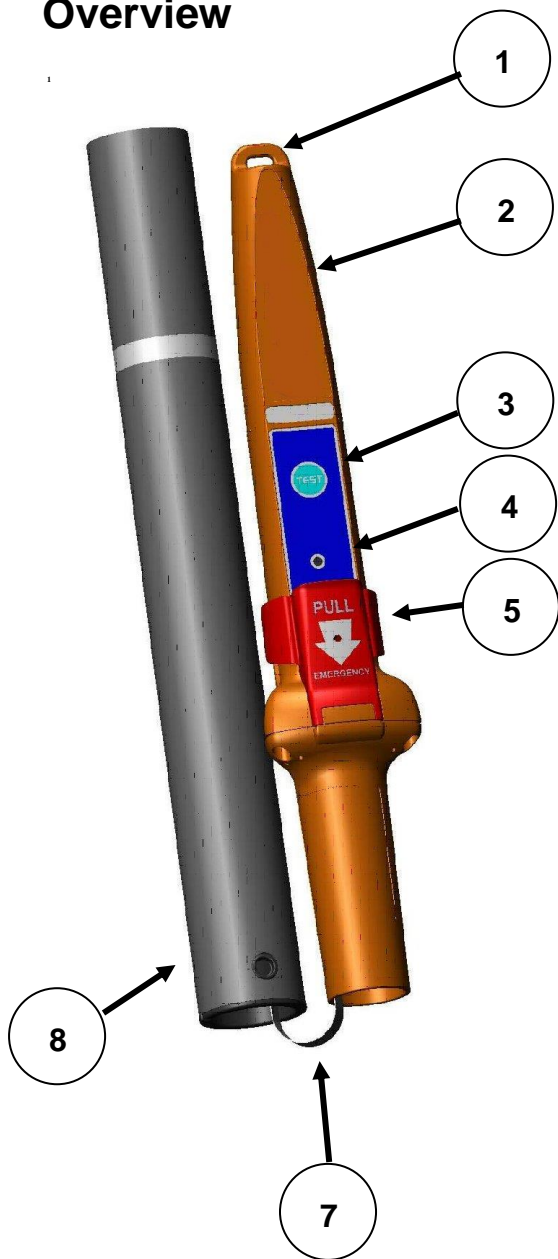

An AIS SART is a “one-shot” device. Once activated it will transmit emergency alerts for at least 96 hours.

The key components of the AIS SART:

1. Hanger eye

Lanyard cord attachment point.

2. Antenna

Contained within top section.

3. Test button

Self-test verifies the readiness of the AIS SART.

4. Red LED

Indicates the operating status.

5. Activation Button

Break off the anti-tamper tab to gain access to the **ON** button

6. GPS Zone

Do not obstruct

7. Metal strap

Flexible retaining link to mounting pole

8. Mounting Pole:

Telescopic pole sections. Fit AIS SART body into mounting pole socket. Remove rubber cover and extend pole sections as required.

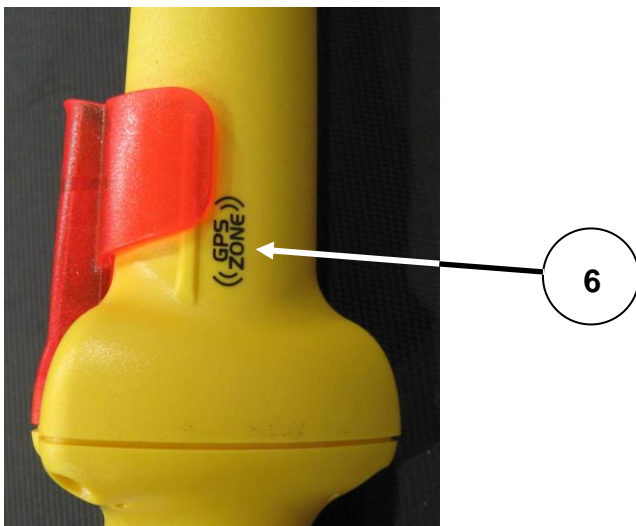



AIS SART pictured left is ready for deployment with the mounting pole fully extended.

The activated AIS SART should be positioned upright and with a clear view of the sky.

Do not obstruct the GPS zone marked on the side.

The AIS SART should be manually erected when the liferaft is deployed.

The antenna datum marked on the pole section should be positioned at least one metre above sea level when the AIS SART is deployed.



TEST button

First Function:

Self test verifies the readiness of the AIS SART.

Second function:

Press and hold the **TEST** button to turn the unit **OFF**



Red LED

Indicates the operating status.



ON button

To activate the AIS SART: Press the **ON** button until the Red LED starts to flash.

To switch off press & hold "TEST"

Deployment procedure

1. Lift stowage case off the wall mounting bracket.
2. Carry to liferaft using the strap provided.
3. Open case and remove the AIS SART.
4. Fold the pole down and insert the AIS SART into the top of the pole.
5. Remove the rubber end cover from the pole and release pole sections.
6. Twist the sections to lock them in fully extended position.

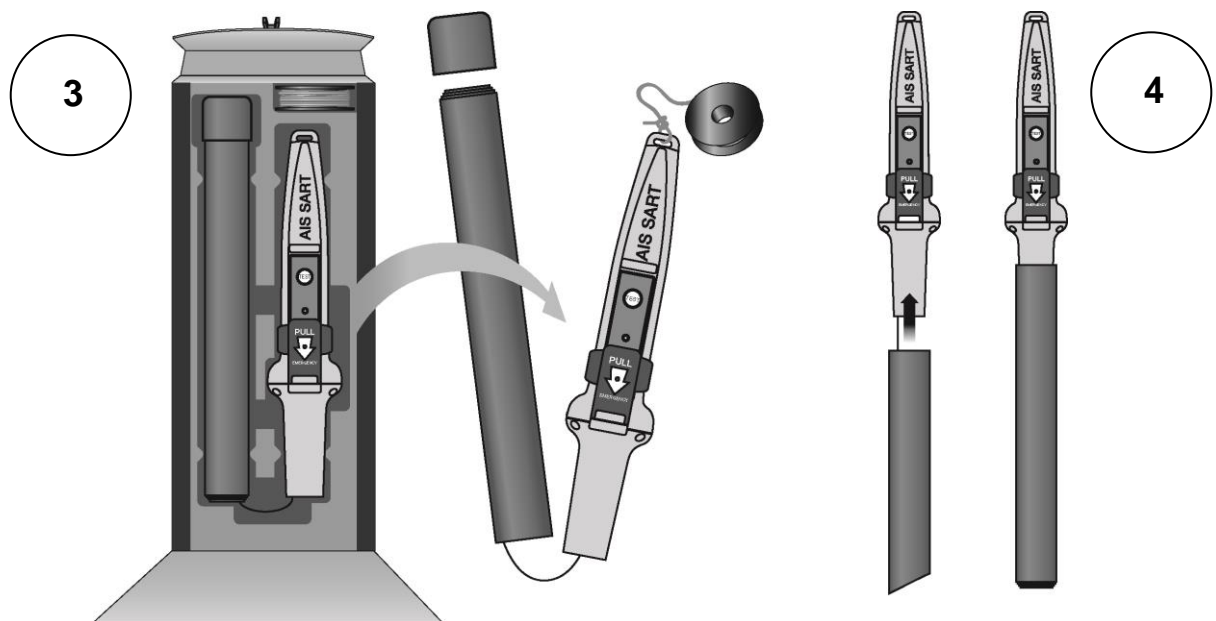
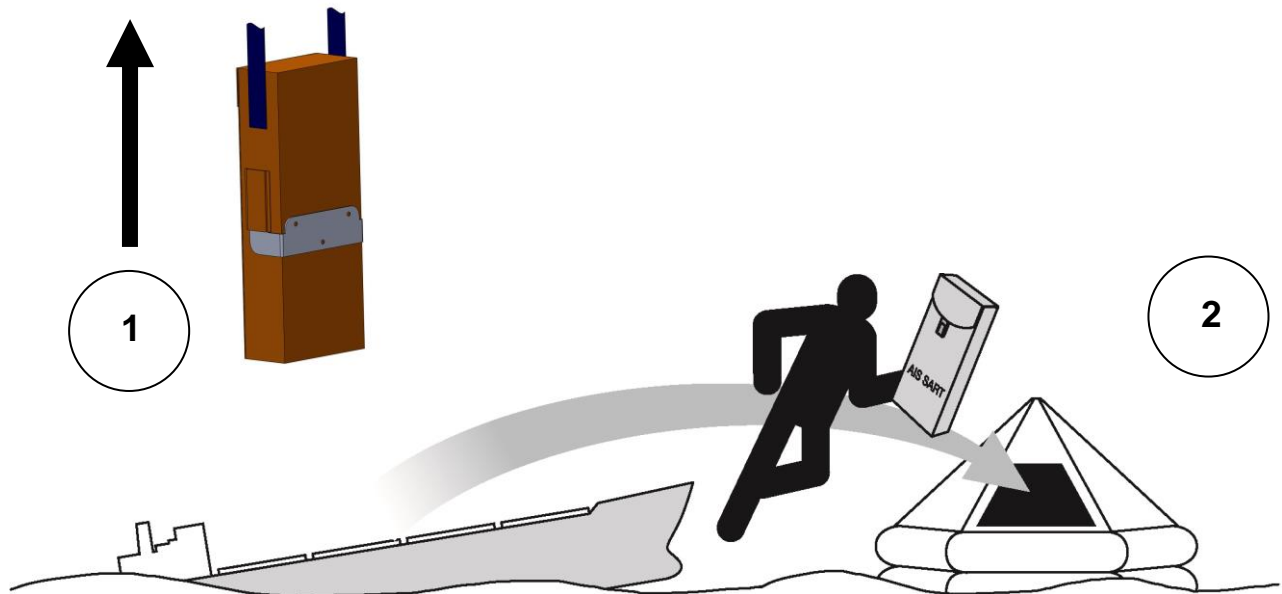

5



6

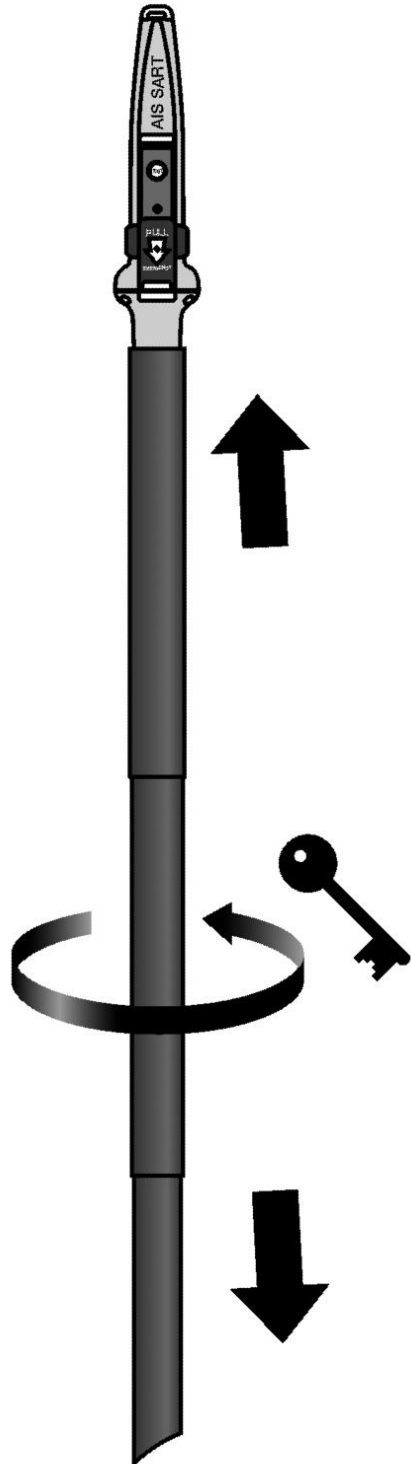

Activation procedure

1. Break-off the protective anti-tamper tab to gain access to the 'ON' button beneath.

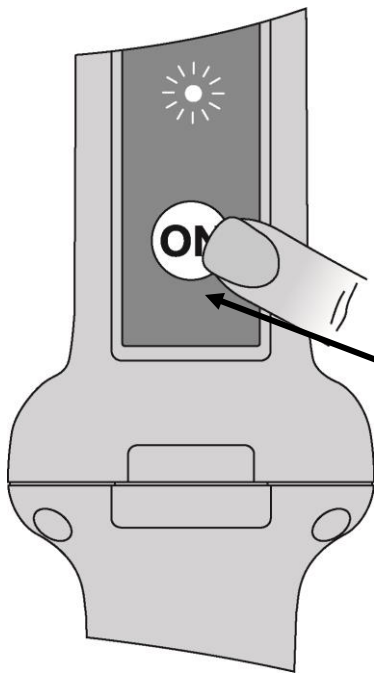
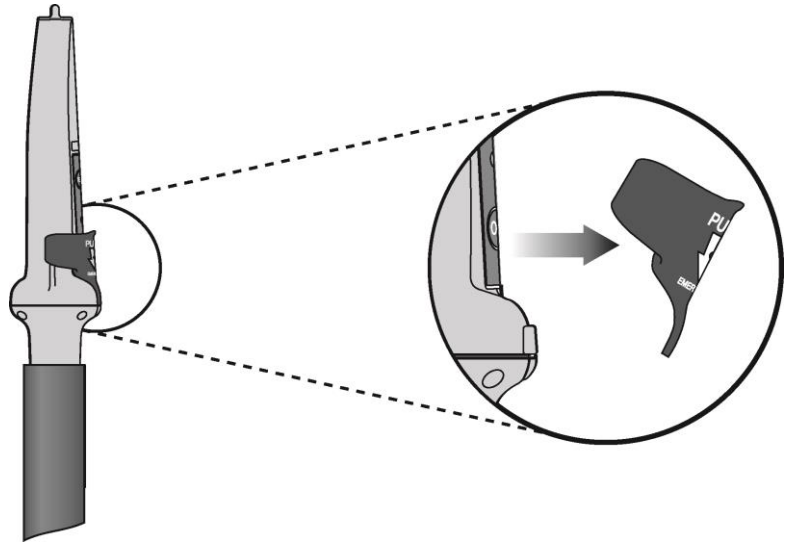

2. Press the 'ON' button



3. The Red LED indicator light will start to flash every few seconds



Red LED indication (AIS SART ON)



1 flash every 3.5 seconds

The first AIS transmission is made after 50 seconds. This short delay allows time to switch off the AIS SART, if activated in error.

4. GPS position fix indication



A good GPS position fix is indicated by the **Red LED** signalling a long flash every minute.

De-activation of the AIS SART

Should the AIS SART be activated by mistake or if the emergency ends; then the AIS SART can be switched **OFF** by depressing the **TEST** button for 2 seconds, the **Red LED** will go out.



Important

After activation the AIS SART requires replacement of the anti-tamper tab and will need a new battery. Refer to service section for further details.

Deployment guidelines

The AIS SART will work best when the top section has an unobstructed view of the sky. Do your best to maximise the sky view. The antenna datum marked on the pole section should be positioned at least one metre above sea level when the AIS SART is deployed.

Tie the securing lanyard to the liferaft to avoid loss of the AIS SART. Activate and then deploy the AIS SART.

Mounting outside a canopy liferaft.

Remove the rubber cover from the bottom of the mounting pole and allow the pole sections to drop. Lock each section together by twisting each section.

Release the lanyard spool and tether the free end of the lanyard to a secure fixing point within the liferaft. Please see the diagram below.

Insert the AIS SART through the SART deployment port in the liferaft canopy. Position the bottom of the support pole within the locating pocket. Secure the pole to the canopy support.

Depending on the type of liferaft, the mounting pole can also be located on the outboard side of the liferaft at the doorway entrance on the boarding ramp side. The AIS SART is mounted in the same way except the pole is secured to the buoyancy support.

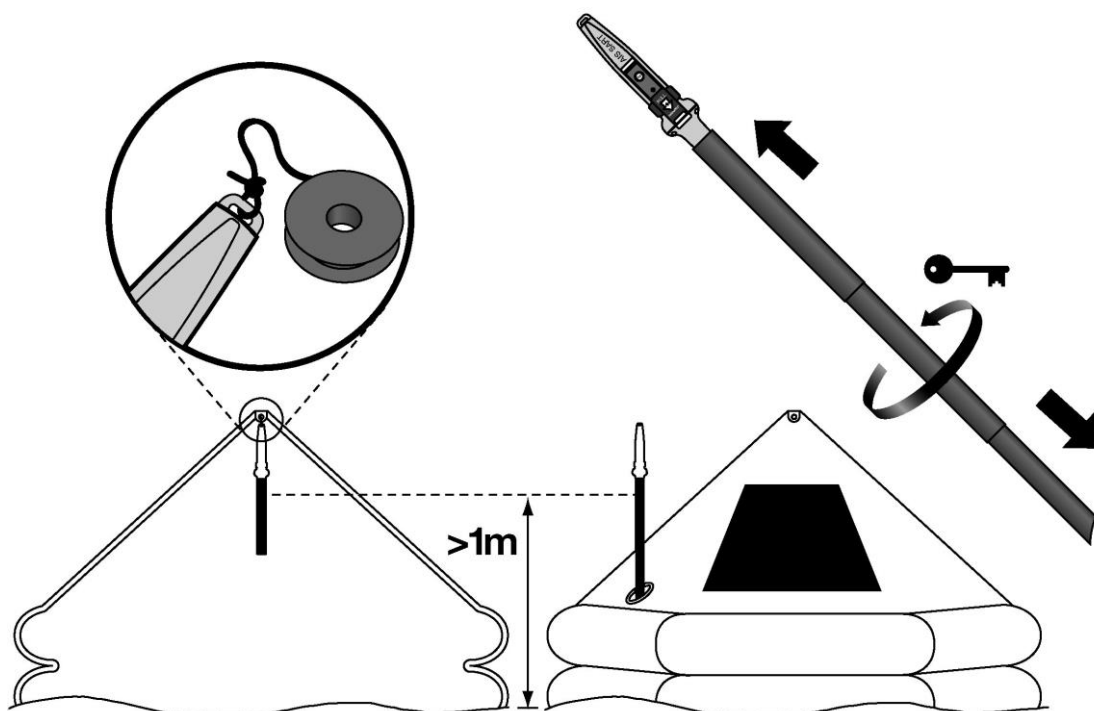

Mounting inside a canopy liferaft.

The SART should be switched **ON** and suspended at highest point of the liferaft by its top loop using the lanyard provided. It is not necessary to fully extend the pole sections.

Self-test of the AIS SART

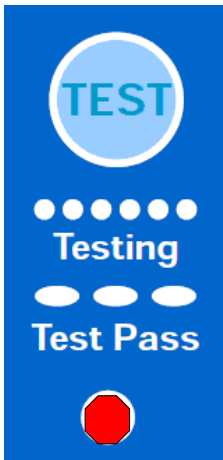

Self test button

Press and hold for 2 seconds to start the self-test routine.

RED LED indicates self test in progress.

It is recommended to self-test the AIS SART annually; more frequent self-testing can put unnecessary drain on the battery. When self-testing, a specially coded AIS test transmission is sent that will be visible to all AIS users in the locality. As a successful self-test result is dependant on a valid GPS acquisition; testing **must** be carried out in the open and under an unobstructed sky.

Self test procedure

Remove the AIS SART from its stowage case and assemble the top section onto the mounting pole. It is not necessary to fully extend the mounting pole. Take the AIS SART outside and **hold it aloft** under a clear view of the sky; this will then maximise the speed of the GPS position fix. Proceed as follows:-

1. Push and hold the TEST button down until the red LED starts to flash.
2. The red LED will flash quickly indicating that the self test routine is in progress.
3. The maximum self-test duration is five minutes (typically 1min)
4. A successful self-test will result in the red LED signalling 3 long flashes.
5. Once the self-test has completed the AIS SART will switch off automatically.

If at the end of the Self-Test routine 3 long flashes are not present from the red LED, the AIS SART has failed the test. In this unlikely event, it is recommended to further improve the sky view and to repeat the self-test procedure.

Self test verification by ships AIS equipment

As part of the self test routine, the AIS SART will make a series of live test transmissions. These transmissions can be received by AIS equipped vessels in the local vicinity. The test message includes the AIS SART's unique 9 digit ID number, position in latitude and longitude and is identified on the receiving AIS equipment as a "SART TEST".

Important

Unnecessary self testing of the AIS SART can reduce the overall run time available in an emergency. Each self test draws a small amount of energy from the battery. If the AIS SART has been activated for a cumulative period in excess of 6 hours (self-test and operation), then the battery must be replaced to ensure that in an emergency it will still operate for a minimum of 96 hours at -20 °C as required by International Regulations.

An AIS SART that fails self-test should be immediately removed from service; refer to the maintenance section for further information.

Refitting into the bulkhead bracket

Fit the AIS SART and accessories inside the stowage case and close the cover and lid.

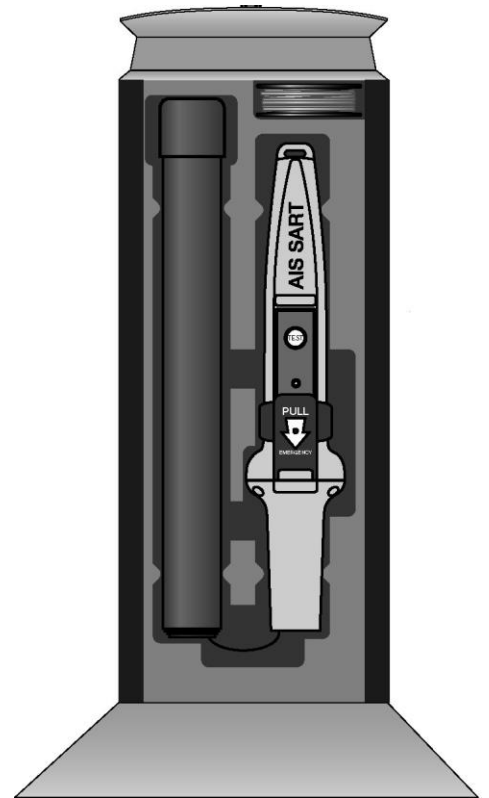

Bracket

Align stowage case over bracket hooks and drop into place. Secure the strap handle around the base of the bag.

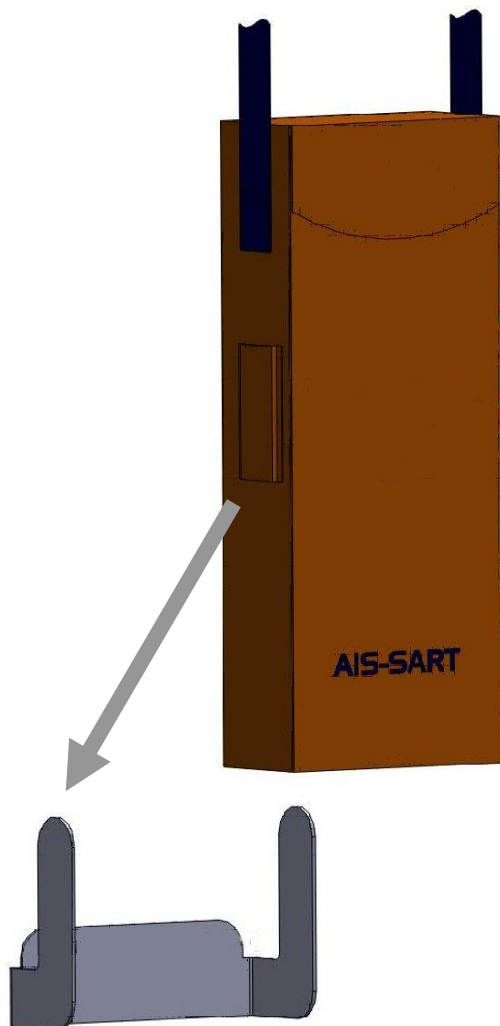

Bulkhead bracket installation

The AIS SART portable stowage case should be located where it will not hinder day-to-day operations. Choose a protected location away from the extreme effects of the weather and protected from powerful vessel wash down hoses. Where possible, position the AIS SART adjacent to the ship's bridge wing exits ready for easy access in an emergency.

The AIS-SART portable stowage case fits over the permanently installed bulkhead bracket. Allow a minimum of 250mm clear space above the highest point of the mounting bracket to allow the bag to be stowed and removed from the bracket.

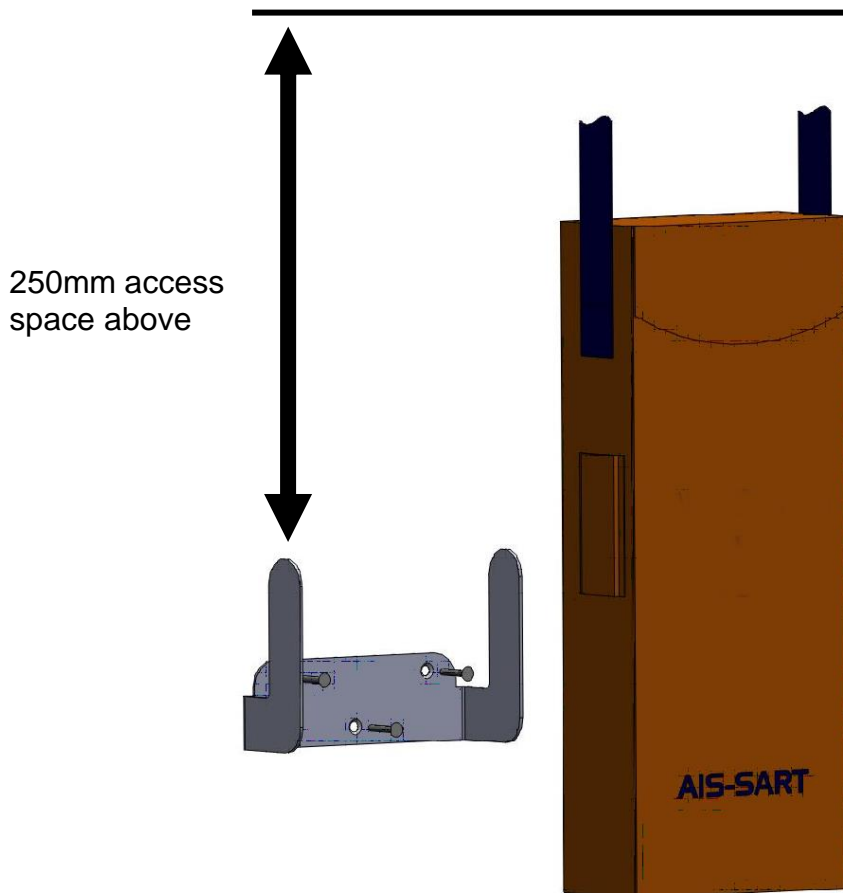

Mounting procedure

The bulkhead bracket is designed to mount on a flat surface using three fixing points. Fix the mounting bracket in place using the three stainless steel screws (25mm in length) provided. Or use stainless steel bolts with locking nuts or shake proof washers.

Check that the rear side of the mounting surface is clear and that the fixing screws will not penetrate equipment fitted on this surface. Offer the bracket into the chosen position and mark through the mounting slots using the bracket as a template.

Drop the AIS SART stowage case over the bracket. Push the bag firmly into place.

Stowage options

The stowage case provides additional protection for the AIS SART if you intend to keep it in a carry off 'safety ditch bag' or when transporting it from place to place.

Dealing with a transmitting AIS SART

In the unlikely event that the AIS SART develops a fault and will not turn off, transmissions can be prevented by removing the lower battery section. To do this, undo the three fixing screws located around the main body. Release the battery pack and unplug the flying battery connector(s). Note: with the battery pack removed the AIS SART (and battery pack) are not waterproof and must not be allowed to get wet.

Refer to product safety warnings.

Routine maintenance

Self test the AIS SART annually. Check that the battery is in date and examine the outer case and bracket for any signs of damage. If required, clean the outer case with fresh water, wipe dry and examine the AIS SART and bracket for any damage.



CAUTION: Never use chemical solvents to clean the AIS SART or stowage case.



CAUTION: The battery may be run down and require replacement (see below).

After activation

The anti-tamper switch cover should be replaced by a service agent and the remaining battery life checked (see below).

Battery replacement

The battery should be changed after five years in service.

The exact battery expiry date is marked on the label of the battery pack.

The battery must be replaced when:

- The expiry date has been reached **or**
- The AIS SART has been activated for more than 6 hours of use.

Servicing

It is recommended that battery change should be performed by an authorised Orolia Ltd service agent in order that a complete assessment and integrity check can be performed. Keep the original packing material for reuse whenever the AIS SART is sent for battery replacement or service.

Spare parts

Item	Part number	Contents
Battery kit	92-057-002A	Battery pack and sealing kit
Anti tamper tab kit	92-051A	Switch cover and sealing kit
Stowage case	92-052-002A	Empty case with packing insert.
Wall mounting kit	92-053A	Bracket and fixings
Lanyard	92-054A	Coiled 10m lanyard
Pole kit	92-055A	Pole with fitting parts
User Manual	92-059-002A	This document

Transportation

Passenger Aircraft;

This product contains small lithium metal batteries. The AIS SART can normally be taken on board a passenger aircraft as a personal item in carry-on hand baggage. We recommend declaring the AIS SART to airline staff at check in, in the same way you would for a laptop PC or video camera.

As air cargo;

This product contains small lithium metal batteries. Due to the overall low level of lithium content the AIS SART may be classed as 'not restricted' for air cargo when handled according to requirement PI 970 of the IATA Dangerous Goods Regulations (51st Edition). Always check with the carrier concerned for any additional shipment restrictions that may apply.

Specifications

Part Number: 92-001-002A Kannad Marine Safelink AIS SART retail pack

Type Operation	IMO AIS SART	Non float free
	Manual activation switch	Protected by anti tamper cover.
	Self test	Checks transmitter, battery, GPS and indicators.
AIS Transmitter	Operating frequency	AIS1, 161.975 MHz AIS2, 162.025 MHz
	Power output	1 W EIRP
	AIS message type	1, 14
	Modulation	GMSK
	Antenna	Integrated vertical element
Battery	Type	Lithium metal
	Operating life	96 hours minimum
	Storage	6 years
	Service	Replaceable
GNSS	GPS	20 channel
Environment	Operating temperature	-20 °C to +55 °C
	Storage temperature	-30 °C to +70 °C
	Waterproof	Immersion to 10m
	Buoyancy	Floats
	Exterior Finish	Highly visible yellow
	Compass safe distance	0.2m
Physical	Weight (main unit)	160 grams
	Weight, (including pole)	450 grams
	Size (main unit pole folded)	H330 x W85 (mm)
	Overall length including pole fully extended	155 cm
	Lanyard	10 m, 50Kg breaking strain
Mounting	Stowage case (packed)	940g H390 x D80 x W150 (mm)
	Bulkhead bracket	230g
Standards applied	AIS SART	IEC 61097 -14, IEC 60945
	Radio	ITU – R M.1371
	GNSS / GPS	IEC 61108-1
	IMO	MSC.246(83)

EC Declaration of Conformity

A copy of the Marine Equipment Directive (MED) Declaration Of Conformity can be obtained on line from:

www.kannadmarine.com/documents

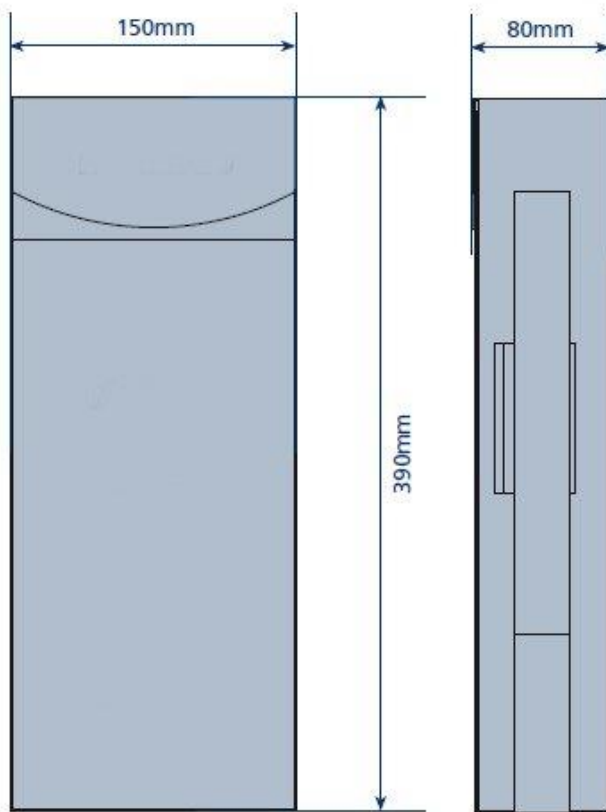

Storage case

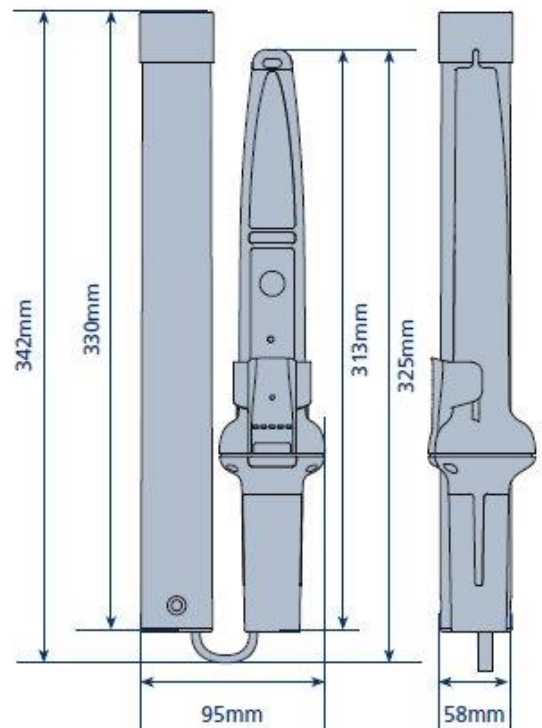

AIS-SART before deployment

End of Life Statement

At the end of the products useful life, it is vital that the battery is removed from the main body of the AIS SART to prevent false alerts. False alerts cause expensive disruption to Search and Rescue services and may endanger lives as a consequence.

Safe disposal

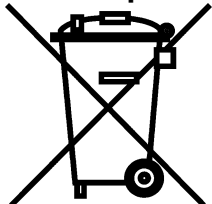

Contains traces of lithium. May contain traces of lead and brominated flame retardants (BFRs), both in the housing material and circuit boards.

DO NOT INCINERATE



Orolia Ltd strongly recommends that this product is disposed of in a sensible and considerate manner. For example, do not simply discard the product in the domestic waste. Instead take it to a civil recycling facility, or contact Orolia Ltd for further advice.

Warranty Statement

Kannad Marine is a brand of Orolia Ltd. Subject to the provisions set out below. Orolia Ltd warrants that this product will be free of defects in materials and workmanship for a period of two years from the date of purchase. Orolia Ltd will not be liable to the buyer under the above warranty:-

- for any defect arising from fair wear and tear, wilful damage, negligence, abnormal working conditions. Failure to follow Orolia Ltd's instructions (whether oral or in writing) including a failure to install properly and/or to use batteries recommended and/or supplied by Orolia Ltd. Misuse or alterations or repair of the product by persons other than Orolia Ltd or an Approved Service Agent;
- for parts, materials or equipment not manufactured by Orolia Ltd in respect of which the buyer shall only be entitled to the benefit of any warranty or guarantee given by the manufacturer to Orolia Ltd;
- for the battery storage life which is specifically excluded from this warranty;
- if the total price for the product has not been paid.

THE LIMITED WARRANTY STATED ABOVE IS EXCLUSIVE AND IN LIEU OF ANY OTHER WARRANTY, EXPRESS OR IMPLIED, INCLUDING BUT NOT LIMITED TO ANY IMPLIED WARRANTY OF MERCHANTABILITY OR FITNESS FOR A PARTICULAR PURPOSE. Orolia Ltd will not be liable for indirect, special, incidental or consequential damages of any kind sustained from any cause. In no event shall Orolia Ltd be liable for any breach of warranty or other claim in an amount exceeding the purchase price of the product. This warranty does not affect any statutory rights of the consumer.

In order to be valid, claims must be made under the above warranty in writing as soon as practicable after discovery of the defect or failure and within the warranty period referred to above. Proof of purchase will be required. The claim should be sent together with the product in question to the address set out below or to an Approved Service Agent.

Following a valid warranty claim Orolia Ltd shall be entitled to repair or replace the product (or part) in question free of charge, or at Orolia Ltd's sole discretion to refund to the buyer the price of the product (or a proportional part of the price). Orolia Ltd shall not be liable to a buyer who is not a consumer for any other loss or damage (whether indirect, special or consequential loss of profit or otherwise) costs, expenses or other claims for compensation which arise out of or in connection with this product. In the case of a consumer Orolia Ltd shall only be liable where other loss or damage is foreseeable.

Nothing shall limit Orolia Ltd's liability for death or personal injury caused by its negligence. This warranty is to be interpreted under English law.

All enquiries relating to this warranty or Approved Service Agents should be sent to:

**Orolia Ltd, Silver Point, Airport Service Road, Portsmouth, Hampshire,
PO3 5PB, UK**

Telephone: Int + 44 (0) 23 9262 3900

Web: www.kannadmarine.com

Fax: Int + 44 (0) 23 9262 3998

Email: service.kannad-ma@orolia.com

THIS PAGE IS INTENTIONALLY BLANK

Orolia Ltd

**Silver Point
Airport Service Road
Portsmouth PO3 5PB
United Kingdom**

Phone: +44 (0)23 9262 3900
Fax: +44 (0)23 9262 3998
Email: service.kannad-ma@orolia.com
Website: www.kannadmarine.com

An Orolia Group Business

92-261 Issue 3